

MOUNTING AND
OPERATING INSTRUCTIONS

EB 8080 EN

Translation of original instructions



Type 3599 Axial Globe Valve
ANSI and DIN versions

Note on these mounting and operating instructions

These mounting and operating instructions assist you in mounting and operating the device safely. The instructions are binding for handling RINGO devices. The images shown in these instructions are for illustration purposes only. The actual product may vary.

- For the safe and proper use of these instructions, read them carefully and keep them for later reference.
- If you have any questions about these instructions, contact RINGO's After-sales Service (Aftersales-ringo-es@samsongroup.com).

Definition of signal words

DANGER

Hazardous situations which, if not avoided, will result in death or serious injury

WARNING

Hazardous situations which, if not avoided, could result in death or serious injury

NOTICE

Property damage message or malfunction

Note

Additional information

Tip

Recommended action

1	Safety instructions and measures	1-1
1.1	Notes on possible severe personal injury	1-5
1.2	Notes on possible personal injury	1-5
1.3	Notes on possible property damage	1-8
1.4	Warnings on the device	1-9
2	Markings on the device	2-1
2.1	Valve nameplate	2-1
2.2	Actuator nameplate	2-1
3	Design and principle of operation	3-1
3.1	Fail-safe action	3-1
3.2	Additional fittings	3-6
3.3	Technical data	3-6
4	Shipment and on-site transport	4-1
4.1	Accepting the delivered goods	4-1
4.2	Removing the packaging from the valve	4-1
4.3	Temporary packing (220) in the bonnet (20)	4-1
4.4	Selecting lifting equipment and accessories	4-1
4.5	Transporting and lifting the valve	4-3
4.5.1	Transporting the valve	4-3
4.5.2	Lifting the valve	4-4
4.6	Storing the valve	4-5
5	Installation	5-1
5.1	Installation conditions	5-1
5.2	Preparation for installation	5-2
5.3	Mounting the device	5-3
5.3.1	Mounting the actuator onto the valve	5-3
5.3.2	Installing the valve into the pipeline	5-4
5.4	Testing the installed valve	5-4
5.4.1	Leakage	5-6
5.4.2	Rotary motion	5-6
5.4.3	Fail-safe position	5-7
5.4.4	Pressure test	5-7
6	Start-up	6-1
7	Operation	7-1
7.1	Normal operation	7-2
7.2	Manual operation	7-2

Contents

8	Malfunctions	8-1
8.1	Troubleshooting	8-1
8.2	Emergency action	8-2
9	Servicing.....	9-1
9.1	Periodic testing	9-3
9.2	Service work preparations	9-5
9.3	Installing the valve after service work.....	9-5
9.4	Service work.....	9-5
9.4.1	Replacing the gaskets on the bonnet and actuator stem	9-5
9.4.2	Replacing the gaskets on the trim	9-7
9.5	Ordering spare parts and operating supplies	9-9
10	Decommissioning	10-1
11	Removal	11-1
11.1	Removing the valve from the pipeline.....	11-2
11.2	Removing the actuator from the valve	11-2
12	Repairs	12-1
12.1	Returning devices to RINGO	12-1
13	Disposal.....	13-1
14	Certificates.....	14-1
15	Appendix.....	15-1
15.1	Tightening torques, lubricants and tools	15-1
15.2	Spare parts	15-4
15.3	After-sales service	15-6

1 Safety instructions and measures

Intended use

The Type 3599 Axial Globe Valve in combination with a 90° rotary actuator is designed to regulate the flow rate, pressure or temperature of liquids or gases. The valve is suitable for throttling and on/off service in critical applications, for example for high flow rates with excellent control accuracy in industries.

The valve with its actuator is designed to operate under exactly defined conditions (e.g. operating pressure, process medium, temperature). Therefore, operators must ensure that the control valve is only used in operating conditions that meet the specifications used for sizing the valve at the ordering stage. In case operators intend to use the control valve in applications or conditions other than those specified, contact RINGO.

RINGO does not assume any liability for damage resulting from the failure to use the device for its intended purpose or for damage caused by external forces or any other external factors.

→ Refer to the technical data and nameplate for limits and fields of application as well as possible uses.

Reasonably foreseeable misuse

The control valve is not suitable for the following applications:

- Use outside the limits defined during sizing and by the technical data
- Use outside the limits defined by the valve accessories connected to the valve

Furthermore, the following activities do not comply with the intended use:

- Use of non-original spare parts
- Performing service and repair work not described

Qualifications of operating personnel

The control valve must be mounted, started up, serviced and repaired by fully trained and qualified personnel only; the accepted industry codes and practices must be observed. According to these mounting and operating instructions, trained personnel refers to individuals who are able to judge the work they are assigned to and recognize possible hazards due to their specialized training, their knowledge and experience as well as their knowledge of the applicable standards.

Explosion-protected versions of this device must be operated only by personnel who has undergone special training or instructions or who is authorized to work on explosion-protected devices in hazardous areas.

Safety instructions and measures

Personal protective equipment

RINGO recommends checking the hazards posed by the process medium being used (e.g.

▶ GESTIS (CLP) hazardous substances database). Depending on the process medium and/or the activity, the protective equipment required includes:

- Protective clothing, gloves, eye protection and respiratory protection in applications with hot, cold and/or corrosive media
 - Wear hearing protection when working near the valve
 - Hard hat
 - Safety harness, e.g. when working at height
 - Safety footwear, if applicable ESD (electrostatic discharge) footwear
- ➔ Check with the plant operator for details on further protective equipment.

Revisions and other modifications

Revisions, conversions or other modifications of the product are not authorized by RINGO.

They are performed at the user's own risk and may lead to safety hazards, for example. Furthermore, the product may no longer meet the requirements for its intended use.

Safety features

The fail-safe position of the control valve upon air supply or control signal failure depends on the actuator used (see associated actuator documentation).

Warning against residual hazards

To avoid personal injury or property damage, plant operators and operating personnel must prevent hazards that could be caused in the control valve by the process medium, the operating pressure, the signal pressure or by moving parts by taking appropriate precautions. Plant operators and operating personnel must observe all hazard statements, warnings and caution notes in these mounting and operating instructions.

Hazards resulting from the special working conditions at the installation site of the valve must be identified in a risk assessment and prevented through the corresponding safety instructions drawn up by the operator.

Responsibilities of the operator

Operators are responsible for proper use and compliance with the safety regulations.

Operators are obliged to provide these mounting and operating instructions as well as the referenced documents to the operating personnel and to instruct them in proper operation.

Furthermore, operators must ensure that operating personnel or third parties are not exposed to any danger.

Operators are additionally responsible for ensuring that the limits for the product defined in the technical data are observed. This also applies to the start-up and shutdown procedures. Start-up and shutdown procedures fall within the scope of the operator's duties and, as such, are not part of these mounting and operating instructions. RINGO is unable to make any statements about these procedures since the operative details (e.g. differential pressures and temperatures) vary in each individual case and are only known to the operator.

Responsibilities of operating personnel

Operating personnel must read and understand these mounting and operating instructions as well as the referenced documents and observe the specified hazard statements, warnings and caution notes. Furthermore, operating personnel must be familiar with the applicable health, safety and accident prevention regulations and comply with them.

Referenced standards, directives and regulations

The control valves comply with the requirements of the European Pressure Equipment Directive 2014/68/EU and the Machinery Directive 2006/42/EC. Valves with a CE marking have a declaration of conformity which includes information about the applied conformity assessment procedure. The 'Certificates' chapter contains this declaration in compliance with Pressure Equipment Directive 2014/68/EU. The declaration in compliance with Machinery Directive 2006/42/EC is available as a separate document for specific orders.

According to the ignition risk assessment performed in accordance with Clause 5.2 of EN 13463-1:2009, the non-electrical control valves do not have their own potential ignition source even in the rare incident of an operating fault. As a result, they do not fall within the scope of Directive 2014/34/EU.

- ➔ For connection to the equipotential bonding system, observe the requirements specified in Clause 6.4 of EN 60079-14 (VDE 0165-1).

Safety instructions and measures

Referenced documentation

The following documents apply in addition to these mounting and operating instructions:

- Mounting and operating instructions for the mounted actuator
- Mounting and operating instructions for mounted valve accessories (positioner, solenoid valve etc.)
- For oxygen service: Manual ► H 01

1.1 Notes on possible severe personal injury

DANGER

Risk of bursting in pressure equipment.

Valves and pipelines are pressure equipment. Excessive pressurization or improper opening can lead to valve components bursting.

- Observe the maximum permissible pressure for valve and plant.
- Before starting any work on the control valve, depressurize all plant sections affected as well as the valve.
- Drain the process medium from the plant sections affected as well as from the valve.

1.2 Notes on possible personal injury

WARNING

Risk of burn injuries due to hot or cold components and pipelines.

Depending on the process medium, valve components and pipelines may get very hot or cold and cause burn injuries.

- Allow components and pipelines to cool down or warm up to the ambient temperature.
- Wear protective clothing and safety gloves.

Risk of hearing loss or deafness due to loud noise.

The noise emissions depend on the valve version, plant facilities and process medium.

- Wear hearing protection when working near the valve.

WARNING

Risk of personal injury due to exhaust air being vented from pneumatically operated components.

When the valve is operated with a pneumatic actuator or pneumatic valve accessories, exhaust air may be vented from the actuator, for example, while the valve is operating in closed-loop control or when the valve opens or closes.

- Install the control valve in such a way that vent openings are not located at eye level and the actuator does not vent at eye level in the work position.
- Use suitable mufflers and vent plugs.
- Wear eye protection when working in close proximity to the control valve.

Crush hazard arising from moving parts.

The control valve has moving parts. The plug in the valve body is moved in a linear motion by the actuator. The actuator stems rotate. This can lead to crush injuries to hands or fingers if they are inserted into the valve.

- Do not insert hands or fingers into the valve body.
- Before working on the control valve, release any energy (in the actuator) which causes the actuator stem to move. This also applies to the actuator springs that are preloaded (see associated actuator documentation).
- Before working on the control valve, disconnect and lock the pneumatic air supply as well as the control signal if they are connected.
- Disconnect the supply voltage if it is connected before performing any work on the control valve.
- Do not impede the movement of the actuator drive and plug by inserting objects into them.
- Before attempting to unblock a plug after it has become blocked (e.g. due to seizing up after remaining in the same position for a long time), release any energy (in the actuator) which causes the actuator stem to move.

Risk of personal injury due to the preloaded actuator springs.

Valves in combination with pneumatic actuators with preloaded springs are under tension.

- Before starting any work on the actuator, relieve the compression from the preloaded springs (see associated actuator documentation).

⚠ WARNING**Risk of personal injury due to residual process medium in the valve.**

While working on the valve, residual medium can flow out of the valve and, depending on its properties, cause personal injury, e.g. (chemical) burns.

- If possible, drain the process medium from the plant sections affected and from the valve.
- Wear protective clothing, safety gloves, respiratory protection and eye protection.

Exposure to hazardous substances poses a serious risk to health.

Certain lubricants and cleaning agents are classified as hazardous substances. These substances have a special label and a material safety data sheet (MSDS) issued by the manufacturer.

- Make sure that an MSDS is available for any hazardous substance used. If necessary, contact the manufacturer to obtain an MSDS.
- Inform yourself about the hazardous substances and their correct handling.

Risk of personal injury due to incorrect operation, use or installation as a result of information on the valve being illegible.

Over time, markings, labels and nameplates on the valve may become covered with dirt or become illegible in some other way. As a result, hazards may go unnoticed and the necessary instructions not followed. There is a risk of personal injury.

- Keep all relevant markings and inscriptions on the device in a constantly legible state.
- Immediately renew damaged, missing or incorrect nameplates or labels.

1.3 Notes on possible property damage

! NOTICE

Risk of damage to the valve trim parts through jolts or shocks

The valve can be fitted with a valve trim made of tungsten carbide to meet high requirements. Tungsten carbide has excellent hardness properties, but is extremely brittle. It can easily fracture under bending load.

- Avoid impacts to the valve.
- Avoid jolts or shocks (e.g. when transporting the valve).

Risk of valve damage due to contamination (e.g. solid particles) in the pipeline.

The plant operator is responsible for cleaning the pipelines in the plant.

- Flush the pipelines before start-up.

Risk of valve damage due to unsuitable medium properties.

The valve is designed for a process medium with defined properties.

- Only use the process medium specified for sizing the equipment.

Risk of leakage and valve damage due to over- or under-torquing.

Observe the specified torques when tightening control valve components. Excessive tightening torques lead to parts wearing out more quickly. Parts that are too loose may cause leakage.

- Observe the specified tightening torques (see the 'Tightening torques, lubricants and tools' chapter in the Appendix).

Risk of valve damage due to the use of unsuitable tools.

Certain tools are required to work on the valve.

- Only use tools approved by RINGO (see the 'Tightening torques, lubricants and tools' chapter in the Appendix).

Risk of valve damage due to the use of unsuitable lubricants.

The lubricants to be used depend on the valve material. Unsuitable lubricants may corrode and damage surfaces.

- Contact RINGO's After-sales Service Department for more information on suitable lubricants.

! NOTICE

Risk of the process medium being contaminated through the use of unsuitable lubricants and/or contaminated tools and components.

- If necessary, keep the valve and the tools used free from solvents and grease.
- Make sure that only suitable lubricants are used.

1.4 Warnings on the device

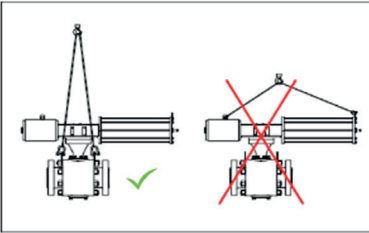
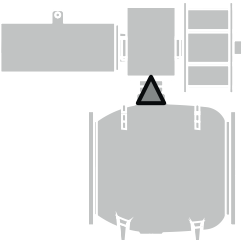
Warning symbols	Meaning of the warning	Location on the device
	<p>Warning against the incorrect attachment of lifting tackle.</p> <p>To lift the entire control valve assembly, the load-bearing slings must be attached to the valve body. The lifting eyelets on the actuator are not designed to bear the entire load of a control valve assembly.</p>	

2 Markings on the device

The nameplate shown was up to date at the time of publication of this document. The nameplate on the device may differ from the one shown.

2.1 Valve nameplate

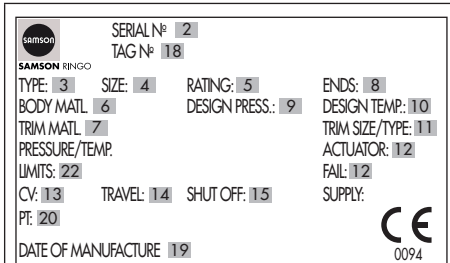

Fig. 2-1: *Inscriptions on the control valve nameplate*

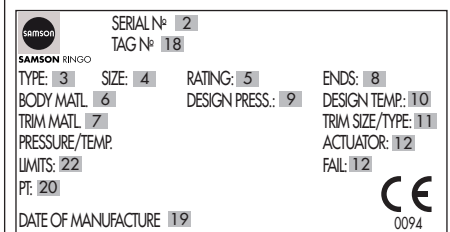

Fig. 2-2: *Inscriptions on the on/off valve nameplate*

Item	Inscription meaning
2	Serial number
3	Type designation
4	Nominal size
5	Pressure rating
6	Body material
7	Trim material
8	Type of connection

Item	Inscription meaning
9	Design pressure
10	Temperature
11	Trim size/type
12	Actuator/fail-safe action
13	Flow coefficient
14	Travel
15	Max. permissible differential pressure
19	Month and year of manufacture
20	Test pressure
22	Pressure and temperature ranges

The nameplate is affixed to the valve body between the lifting eyelets (see Fig. 2-3).

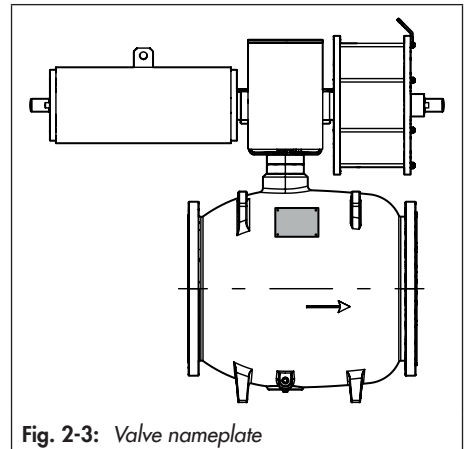

Fig. 2-3: *Valve nameplate*

2.2 Actuator nameplate

See associated actuator documentation.

3 Design and principle of operation

See Fig. 3-2 and Fig. 3-3

The Type 3599 Valve is a compact globe valve with axial flow technology, which can be combined with all 90° rotary actuators to form a control valve.

The control valve is designed for both throttling and on/off service and is suitable for high flow rates and meets demands concerning a high level of control accuracy. The control valve is suitable for liquids and gases at temperatures from -60 to +200 °C (-76 to +392 °F) and pressure rating of PN 10 to 420/Class 150 and 1200.

The medium flows through the valve in the direction indicated by the arrow. The balanced plug is located axially in the flow path of the pipeline. The drive mechanism, which is protected from the process medium, converts the rotational motion of the actuator stem into a linear motion to move the plug. The plug moves forward to the outlet port to open the valve. The cross-section of the cage released by the plug determines the flow rate through the valve and the pressure p_2 . The cage is available in four versions:

- **STD:** cage with standard hole pattern for non-critical applications
- **LDB (lowdB):** cage with small-sized hole pattern to reduce noise emissions
- **Cavless:** cage with specially shaped holes which create a Venturi effect to protect against cavitation

- **DobCage:** combination of two LDB cages with small spacing and offset between the cages to achieve maximum noise protection through a multi-state effect

A valve version without cage can be used to achieve higher flow capacity for on/off service.

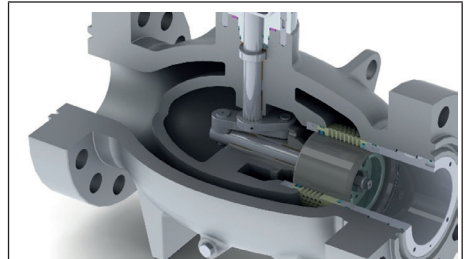

Fig. 3-1: Inside view of Type 3599 Valve

3.1 Fail-safe action

The fail-safe position of the control valve upon air supply or control signal failure depends on the actuator used (see associated actuator documentation).

Design and principle of operation

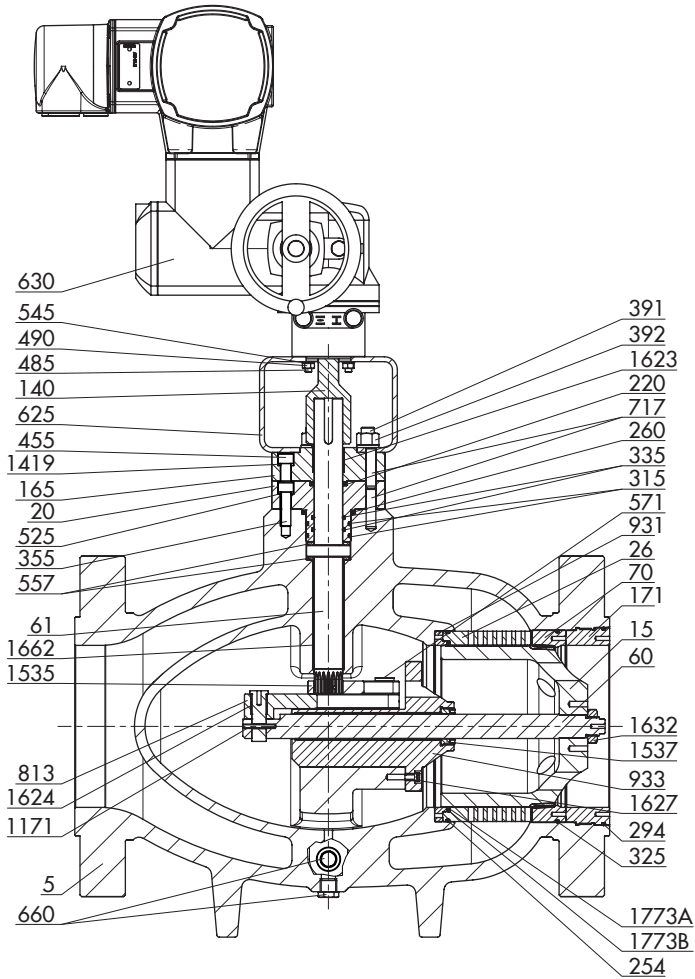

Fig. 3-2: Type 3599 Valve with electric rotary actuator

Legend for Fig. 3-2

5	Body	335	O-ring (plug stem)	931	Balancing cylinder
15	Flat plug	355	Bolt	933	Guide bushing
20	Bonnet	391	Stud	1171	Locking pin
26	Cage	392	Nut	1419	Washer
60	Plug stem	455	Bolt	1535	Stem connector
61	Actuator stem	485	Screw	1537	Guide bushing stop
70	Seat ring	490	Nut	1622	Guide bushing (actuator stem)
140	Plug stem extension	525	Washer	1623	Bushing (actuator stem)
165	Connecting flange	545	Washer	1624	Bushing
171	Retaining ring	557	Thrust washer	1627	Bolt
220	Packing	571	Pin	1632	Nut
254	Seal	625	Yoke	1773A	O-ring (cage)
260	Gasket (bonnet)	630	Electric actuator	1773B	O-ring (cage)
294	O-ring (body)	660	Drain screw		
315	O-ring (bonnet)	717	Threaded pin (bonnet)		
325	O-ring (trim)	813	Drive rod		

Design and principle of operation

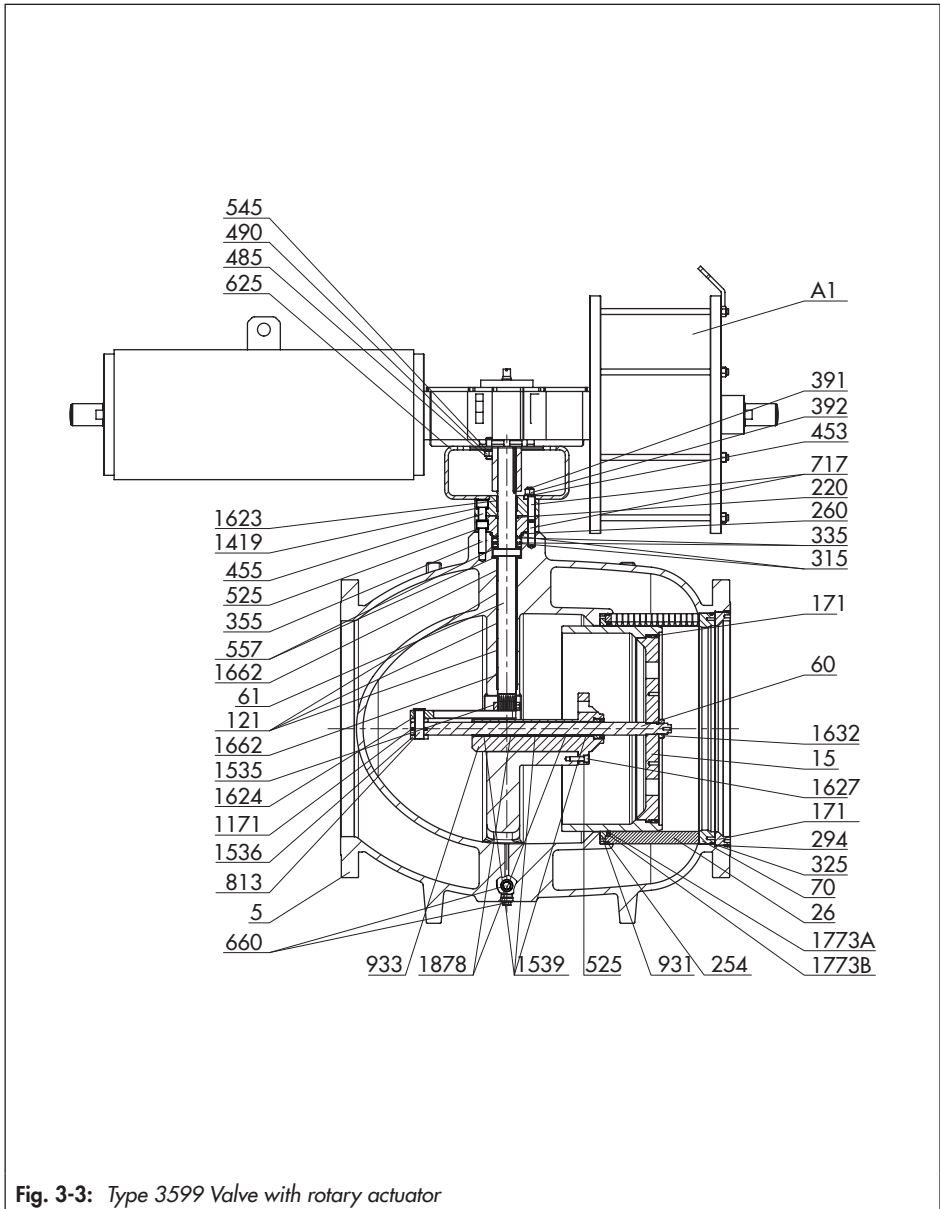

Fig. 3-3: Type 3599 Valve with rotary actuator

Legend for Fig. 3-3

A1	Actuator	355	Bolt	1171	Locking pin
5	Body	391	Stud	1419	Washer
15	Flat plug	392	Nut	1535	Stem connector
26	Cage	453	Spring washer	1536	Rod pin
60	Plug stem	455	Bolt	1539	Slip bushing
61	Actuator stem	485	Screw	1622	Guide bushing (actuator stem)
70	Seat ring	490	Nut	1623	Bushing (actuator stem)
121	Spacer sleeve	525	Washer	1624	Bushing
171	Retaining ring	545	Washer	1627	Bolt
220	Packing	557	Thrust washer	1632	Nut
254	Seal	625	Yoke	1773A	O-ring (cage)
260	Seal	660	Drain screw	1773B	O-ring (cage)
294	O-ring (body)	717	Threaded pin (bonnet)	1878	Spacer sleeve
315	O-ring (bonnet)	813	Drive rod		
325	O-ring (seat)	931	Balancing cylinder		
335	O-ring (plug stem)	933	Guide bushing		

3.2 Additional fittings

Strainer

RINGO recommends installing a strainer upstream of the valve. It prevents solid particles in the process medium from damaging the valve.

Bypass and shut-off valves

RINGO recommends installing a shut-off valve both upstream of the strainer and downstream of the valve and installing a bypass line. The bypass ensures that the plant does not need to be shut down for service and repair work on the valve.

Safety guard

For operating conditions that require increased safety (e.g. in cases where the valve is freely accessible to untrained staff), a safety guard must be installed to rule out a crush hazard arising from moving parts (actuator stems). Plant operators are responsible for deciding whether a guard is to be used. The decision is based on the risk posed by the plant and its operating conditions.

Noise reduction

DobCage trims with more than two stages are available on request to further reduce noise emissions.

3.3 Technical data

The nameplates on the valve and actuator provide information on the control valve version. See the 'Markings on the device' chapter.

i Note

*More information is available in Data Sheet
▶ T 8080.*

Noise emissions

RINGO is unable to make general statements about noise emissions. The noise emissions depend on the valve version, plant facilities and process medium.

Table 3-1: Technical data for Type 3599 Valve

Nominal size		Cast body		
		NPS 4 to 48	DN 100 to 1200	
Pressure rating		Class 150 to 2500	PN 10 to 420	
Type of connection	Flanges	ASME B16.34 RF	•	–
		ASME B16.34 RTJ	•	–
		DIN EN 558	–	•
Characteristic		Equal percentage · Linear · Others on request		
Conformity		CE		
Permissible temperature range				
Valve trim	STD	–76 to +392 °F (–60 to +200 °C) ¹⁾		
	LDB	–76 to +392 °F (–60 to +200 °C) ¹⁾		
	Cavless	–76 to +392 °F (–60 to +200 °C) ¹⁾		
	DobCage	–76 to +392 °F (–60 to +200 °C) ¹⁾		
Leakage class according to IEC 60534-4				
Valve plug	Metal seal	IV or V		
	Soft seal	VI		

¹⁾ Other temperature ranges on request

Design and principle of operation

Dimensions and weights ¹⁾

Dimensions in mm · Weights ²⁾ in kg

Table 3-1.1: ANSI flanged body version RF and RTJ · NPS 4 to 18

Dim.	Pressure rating	Nominal size NPS								
		4	6	8	10	12	14	16	18	
Length L	Class 150	in	17.01	15.51	17.99	20.98	24.02	27.01	30.00	34.02
		mm	432	394	457	533	610	686	762	864
	Class 300	in	17.01	15.87	19.76	22.36	25.51	30.00	32.99	35.98
		mm	432	403	502	568	648	762	838	914
	Class 600	in	17.01	22.01	25.98	30.98	32.99	35.00	39.02	42.99
		mm	432	559	660	787	838	889	991	1092
	Class 900	in	17.99	24.02	29.02	32.99	37.99	40.51	44.49	47.99
		mm	457	610	737	838	965	1029	1130	1219
	Class 1500	in	21.50	27.76	32.76	39.02	44.49	49.49	54.49	60.12
		mm	546	705	832	991	1130	1257	1384	1527
	Class 2500	in	26.50	35.98	40.24	50.00	55.98	On request		
		mm	673	914	1022	1270	1422			
Height H2	Class 150	in	6.50	7.48	8.78	10.16	11.57	12.68	14.25	15.63
		mm	165	190	223	258	294	322	362	397
	Class 300	in	7.01	8.27	9.45	9.96	11.81	13.50	14.76	16.06
		mm	178	210	240	253	300	343	375	408
	Class 600	in	7.40	8.98	10.24	12.01	13.78	14.96	16.14	17.40
		mm	188	228	260	305	350	380	410	442
	Class 900	in	7.68	9.45	11.22	12.64	13.98	14.61	16.38	18.19
		mm	195	240	285	321	355	371	416	462
	Class 1500	in	8.07	9.65	11.54	13.50	15.28	16.73	18.23	20.00
		mm	205	245	293	343	388	425	463	508
	Class 2500	in	8.98	11.54	12.80	15.28	16.93	On request		
		mm	228	293	325	388	430			

¹⁾ Dimensions and weights for DIN version of Type 3599 Valve on request

²⁾ The weights specified apply to a specific standard device configuration. Weights of other valve configurations may differ depending on the version (material, trim etc.).

Dim.	Pressure rating	Nominal size NPS								
		4	6	8	10	12	14	16	18	
Height H4	Class 150	in	12.76	11.63	13.49	15.74	18.01	20.26	22.64	25.51
		mm	324	295.5	342.75	399.75	457.5	514.5	575	648
	Class 300	in	13.95	13.01	16.21	20.39	18.70	24.60	27.05	29.51
		mm	354.24	330.46	411.64	518	475	624.84	687.16	749.48
	Class 600	in	11.57	14.97	16.85	21.07	23.03	24.88	29.13	30.31
		mm	293.76	380.12	428	535.16	585	632	740	770
	Class 900	in	12.23	16.33	19.73	21.93	25.83	27.55	30.25	35.83
		mm	310.76	414.8	501.16	557	656.2	699.72	768.4	910
	Class 1500	in	12.25	15.79	18.67	22.24	25.36	28.21	31.06	34.27
		mm	311.22	401	474.24	564.87	644.1	716.49	788.88	870.39
	Class 2500	in	15.90	21.59	24.14	30.00	33.59	On request		
		mm	403.8	548.4	613.2	762	853.2			
Weight	Class 150	kg	69.3	115.5	202.4	275	385	495	656	880
	Class 300	kg	72.42	112.2	193.8	285	402	550.8	734.4	948.6
	Class 600	kg	103.2	206.4	310	528.9	711	920	1300	1656
	Class 900	kg	155	310	539.4	817	1202.8	1512.8	1996.4	2405
	Class 1500	kg	179.8	370	649.6	1090.4	1693.6	2227.2	2992.8	3770
	Class 2500	kg	294	669	1088	1975	4088	On request		

Design and principle of operation

Table 3-1.2: ANSI flanged body version RF and RTJ · NPS 20 to 48

Dimension	Pressure rating	Nominal size NPS									
		20	24	28	30	32	36	40	48		
Length L	Class 150	in	35.98	42.01	49.02	50.98	54.02	60.00	65.98	On request	
		mm	914	1067	1245	1295	1372	1524	1676		
	Class 300	in	39.02	45.00	52.99	55.00	60.00	67.99	73.62		
		mm	991	1143	1346	1397	1524	1727	1870		
	Class 600	in	47.01	55.00	62.99	65.00	70.00	82.01	92.01		
		mm	1194	1397	1600	1651	1778	2083	2337		
	Class 900	in	52.01	60.98	69.02	72.99	77.13	85.24	93.50		
		mm	1321	1549	1753	1854	1959	2165	2375		
	Class 1500	in	65.51	76.26	On request						
		mm	1664	1937							
Class 2500	in	On request									
	mm										
Height H2	Class 150	in	16.73	19.72	21.57	23.07	24.29	26.93	29.88	On request	
		mm	425	501	548	586	617	684	759		
	Class 300	in	17.40	20.51	22.87	23.90	25.75	29.09	31.26		
		mm	442	521	581	607	654	739	794		
	Class 600	in	19.69	22.83	25.12	26.42	28.31	31.61	32.83		
		mm	500	580	638	671	719	803	834		
	Class 900	in	19.88	23.11	26.02	29.13	29.25	32.64	34.49		
		mm	505	587	661	740	743	829	876		
	Class 1500	in	21.38	25.00	On request						
		mm	543	635							
Class 2500	in	On request									
	mm										

Dimension	Pressure rating	Nominal size NPS									
		20	24	28	30	32	36	40	48		
Height H4	Class 150	in	26.99	31.51	36.76	38.24	40.51	45.00	49.49	On request	
		mm	685.5	800.25	933.75	971.25	1029	1143	1257		
	Class 300	in	31.99	36.90	43.45	45.10	49.20	55.75	60.37		
		mm	812.62	937.26	1103.72	1145.54	1249.68	1416.14	1533.4		
	Class 600	in	31.22	35.47	42.83	44.20	47.60	55.77	62.57		
		mm	793	901	1088	1122.68	1209.04	1416.44	1589.16		
	Class 900	in	35.37	41.47	46.93	46.89	52.45	57.96	63.58		
		mm	898.28	1053.32	1192.04	1191	1332.12	1472.2	1615		
	Class 1500	in	37.34	43.47	On request						
		mm	948.48	1104.09							
	Class 2500	in	On request								
		mm									
Weight	Class 150	kg	1067	1705	2508	3069	3597	4895	6303	On request	
	Class 300	kg	1173	1836	2703	3223.2	3774	4998	6018		
	Class 600	kg	2110	3334	4631.1	5611.5	6514.5	9094.5	11223		
	Class 900	kg	3087.6	5257.6	6882	8315	9796	13392	16616		
	Class 1500	kg	4814	7830	On request						
	Class 2500	kg	On request								

Design and principle of operation

Dimensional drawing

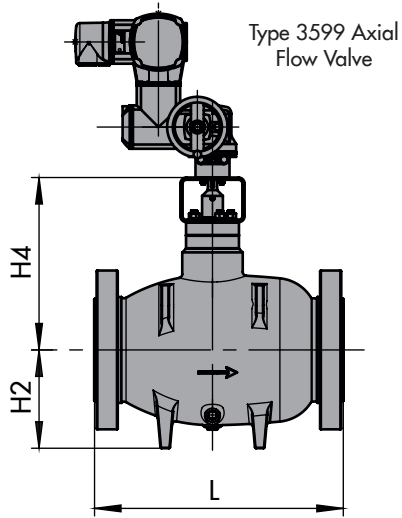

4 Shipment and on-site transport

The work described in this chapter is to be performed only by personnel appropriately qualified to carry out such tasks.

4.1 Accepting the delivered goods

After receiving the shipment, proceed as follows:

1. Check the scope of delivery. Check that the specifications on the valve nameplate match the specifications in the delivery note. See the 'Markings on the device' chapter for nameplate details.
2. Check the shipment for transportation damage. Report any damage to RINGO and the forwarding agent (refer to delivery note).
3. Determine the weight and dimensions of the units to be lifted and transported in order to select the appropriate lifting equipment and lifting accessories. Refer to the transport documents and the 'Technical data' chapter.

4.2 Removing the packaging from the valve

Observe the following sequence:

- Do not open or remove the packaging until immediately before lifting to install the valve into the pipeline.

- Leave the control valve in its transport container or on the pallet to transport it on site.
- Do not remove the protective caps from the inlet and outlet until immediately before installing the valve into the pipeline. They prevent foreign particles from entering the valve.
- Dispose and recycle the packaging in accordance with the local regulations.

4.3 Temporary packing (220) in the bonnet (20)

In some cases, valves designed with a packing around the actuator stem (61) may be fitted with a temporary packing (220) with the exclusive purpose of protecting parts during transportation.

Valves fitted with a temporary packing for transportation are marked accordingly.

Before start-up of such valves, the temporary packing must be replaced with the permanent packing (220).

- Contact our after-sales service to replace the temporary packing.

4.4 Selecting lifting equipment and accessories

Lifting equipment and accessories which are used to transport and lift the control valve must meet the following conditions:

- The lifting equipment and accessories must be approved and suitable.

Shipment and on-site transport

- The lifting capacity of any piece of lifting equipment and accessories to be used must comply with the total weight of the load being transported.
- Metal slings (e.g. chains or wire ropes) must be made of stainless steel to prevent contaminating of stainless steel valves.
- Metal slings (e.g. chains or wire ropes) must have canvas or plastic covering to prevent the valve from being damaged.

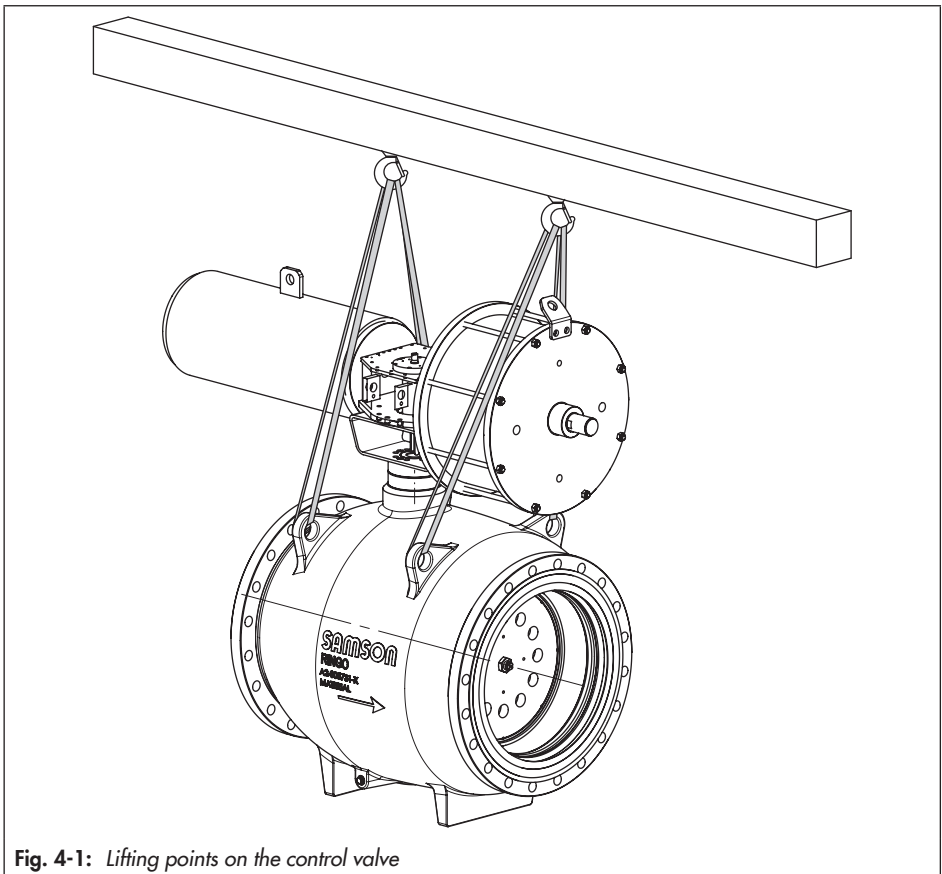

Fig. 4-1: *Lifting points on the control valve*

4.5 Transporting and lifting the valve

DANGER

Danger due to suspended loads falling.

- Stay clear of suspended or moving loads.
- Close off and secure the transport paths.

WARNING

Risk of lifting equipment tipping over and risk of damage to lifting accessories due to exceeding the rated lifting capacity.

- Only use approved lifting equipment and accessories whose minimum lifting capacity is higher than the weight of the valve (including actuator and packaging, if applicable).

WARNING

Risk of personal injury due to the control valve tipping over.

- Observe the valve's center of gravity.
- Secure the valve against tipping over or turning.

NOTICE

Risk of damage to the valve trim parts through jolts or shocks

The valve can be fitted with a valve trim made of tungsten carbide to meet high requirements. Tungsten carbide has excellent hardness properties, but is extremely brittle. It can easily fracture under bending load.

- Avoid impacts to the valve.
- Avoid jolts or shocks (e.g. when transporting the valve).

NOTICE

Risk of valve damage due to incorrectly attached slings.

Do not use lifting eyelets/eyebolts on the actuator to lift the entire control valve assembly.

- When lifting the control valve, make sure that the slings attached to the valve body bear the entire load.
- Do not attach load-bearing slings to the actuator, handwheel or any other parts.
- Observe lifting instructions (see Chapter 4.5.2).

Tip

Our after-sales service can provide more detailed transport and lifting instructions on request.

The valve is delivered in the closed trim position to protect the seat facing from damage.

- Leave the valve in the closed position until installing the valve into the pipeline.

4.5.1 Transporting the valve

The control valve can be transported using lifting equipment (e.g. crane or forklift).

- Leave the control valve in its transport container or on the pallet to transport it.
- Observe the transport instructions.

Shipment and on-site transport

Transport instructions

- Protect the control valve against external influences (e.g. impact or jolts).
- Do not damage the corrosion protection (paint, surface coatings). Repair any damage immediately.
- Protect the piping and any mounted valve accessories against damage.
- Protect the control valve against moisture and dirt.
- The permissible transportation temperature of standard control valves is -20 to $+65$ °C/ -4 to $+149$ °F.

i Note

Contact our after-sales service for the transportation temperatures of other valve versions.

4.5.2 Lifting the valve

To install the valves into the pipeline, use lifting equipment (e.g. crane or forklift) to lift them.

Lifting instructions

- Use a hook with safety latch (see Fig. 4-1) to secure the slings from slipping off the hook during lifting and transporting.
 - Secure slings against slipping.
 - Make sure the slings can be removed from the device once it has been installed into the pipeline.
- Prevent the control valve from tilting or tipping over.
 - Do not leave loads suspended when interrupting work for longer periods of time.
 - Make sure that the axis of the pipeline is always horizontal during lifting and the axis of the actuator stem is always vertical.
 - Make sure that the additional sling between the lashing point on the actuator and rigging equipment (hook, shackle etc.) does not bear any load when lifting valves with an actuator that has a lifting eyelet/eyebolt on it. The sling only protects the control valve from tilting while being lifted. Before lifting the control valve, tighten the sling.

Lifting the control valve

1. Attach one sling to the transport eyelets on the valve body and to the hooks on the crossbeam (see Fig. 4-1).
2. Attach the crossbeam to the rigging equipment.
3. To stabilize the position, attach other slings to the lashing point on the actuator and to the rigging equipment, if necessary.
4. Carefully lift the control valve. Check whether the lifting equipment and accessories can bear the weight.
5. Move the control valve at an even pace to the site of installation.
6. Install the valve into the pipeline (see the 'Installation' chapter).

7. After installation in the pipeline, check whether the flanges are bolted tight and the valve in the pipeline holds.
8. Remove slings.

4.6 Storing the valve

! NOTICE

Risk of valve damage due to improper storage.

- Observe the storage instructions.
- Avoid long storage times.
- Contact RINGO in case of different storage conditions or longer storage periods.

! NOTICE

Risk of damage to the valve trim parts through jolts or shocks

The valve can be fitted with a valve trim made of tungsten carbide to meet high requirements. Tungsten carbide has excellent hardness properties, but is extremely brittle. It can easily fracture under bending load.

- Avoid impacts to the valve.
- Avoid jolts or shocks (e.g. when transporting the valve).

i Note

RINGO recommends to regularly check the control valve and the prevailing storage conditions during long storage periods.

Storage instructions

- Store the valve in the closed trim position to protect the seat facing from damage.
- Do not remove the packaging if the valve is to be kept in storage.
- Store the valve in roofed, closed buildings.
- Protect the control valve against external influences (e.g. impact).
- Secure the valve in the stored position against slipping or tipping over.
- Do not damage the corrosion protection (paint, surface coatings). Repair any damage immediately.
- Protect the control valve against moisture and dirt. Store it at a relative humidity of less than 75 %. In damp spaces, prevent condensation. If necessary, use a drying agent or heating.
- Make sure that the ambient air is free of acids or other corrosive media.
- The permissible storage temperature of standard control valves is –20 to +65 °C/–4 to +149 °F. Contact our after-sales service for the storage temperatures of other valve versions.
- Do not place any objects on the control valve.

Special storage instructions for elastomers

Elastomer, e.g. actuator diaphragm

- To keep elastomers in shape and to prevent cracking, do not bend them or hang them up.

Shipment and on-site transport

- RINGO recommends a storage temperature of 15 °C (59 °F) for elastomers.
- Store elastomers away from lubricants, chemicals, solutions and fuels.



Our after-sales service can provide more detailed storage instructions on request.

5 Installation

The work described in this chapter is to be performed only by personnel appropriately qualified to carry out such tasks.

5.1 Installation conditions

Work position

The work position for the control valve is the front view looking onto the operating controls (including valve accessories).

Plant operators must ensure that, after installation of the device, the operating personnel can perform all necessary work safely and easily access the device from the work position.

Pipeline routing

The inlet and outlet lengths (see Table 5-1) vary depending on several variables and process conditions and are intended as recommendations. Contact RINGO if the lengths are significantly shorter than the recommended lengths.

Table 5-1: Inlet and outlet lengths

State of process medium	Valve conditions	Inlet length a	Outlet length b
Gas	$Ma \leq 0.3$	2	4
	$0.3 \leq Ma \leq 0.7$	2	10
Liquid	Free of cavitation/ $w < 10$ m/s	2	4
	Cavitation producing noise/ $w \leq 3$ m/s	2	4
	Cavitation producing noise/ $3 < w < 5$ m/s	2	10
	Critical cavitation/ $w \leq 3$ m/s	2	10
	Critical cavitation/ $3 < w < 5$ m/s	2	20
Flashing	–	2	20
Multi-phase	–	10	20

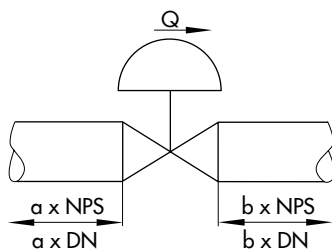

Q Flow rate
a Inlet length
b Outlet length

Installation

To ensure that the valve functions properly, proceed as follows:

- Observe the recommended inlet and outlet lengths (see Table 5-1). Contact RINGO if the valve conditions or state of the medium process deviate.
- Install the valve free of stress and with the least amount of vibrations as possible. Read information under “Mounting position” and “Support or suspension” in this chapter.
- Install the valve allowing sufficient space to remove the actuator and valve or to perform service and repair work on them.

Mounting position

The control valve must be installed in horizontal pipelines in such a way that the actuator stem (61) of the valve points upward.

- Other mounting positions are only permissible after consulting RINGO.

Support or suspension

i Note

The plant engineering company is responsible for selecting and implementing a suitable support or suspension of the installed control valve and the pipeline.

Depending on the valve version and mounting position, the valve, actuator and pipeline must be supported or suspended.

Valve accessories

- During connection of valve accessories, make sure that they are easily accessible

and can be operated safely from the work position.

Vent plugs

Vent plugs are screwed into the exhaust air ports of pneumatic and electropneumatic devices. They ensure that any exhaust air that forms can be vented to the atmosphere (to avoid excess pressure in the device). Furthermore, the vent plugs allow air intake to prevent a vacuum from forming in the device.

- Locate the vent plug on the opposite side to the work position of operating personnel.

5.2 Preparation for installation

Before installation, make sure the following conditions are met:

- The valve is clean.
- The valve and all valve accessories (including piping) are not damaged.
- The valve data on the nameplate (type designation, nominal size, material, pressure rating and temperature range) match the plant conditions (nominal size and pressure rating of the pipeline, medium temperature etc.). See the 'Markings on the device' chapter for nameplate details.
- The requested or required additional pipe fittings (see section 'Additional fittings' in the 'Design and principle of operation' chapter) have been installed or prepared as necessary before installing the valve.

Proceed as follows:

- Lay out the necessary material and tools to have them ready during installation work.
- Flush the pipelines.

i Note

The plant operator is responsible for cleaning the pipelines in the plant.

- Check any mounted pressure gauges to make sure they function properly.
- When the valve and actuator are already assembled, check the tightening torques of the bolted joints. Components may loosen during transport.

5.3 Mounting the device

The activities listed below are necessary to install the valve and before it can be started up.

! NOTICE

Risk of damage to the valve trim parts through jolts or shocks

The valve can be fitted with a valve trim made of tungsten carbide to meet high requirements. Tungsten carbide has excellent hardness properties, but is extremely brittle. It can easily fracture under bending load.

- Avoid impacts to the valve.
 - Avoid jolts or shocks (e.g. when transporting the valve).
-

! NOTICE

Risk of control valve damage due to over- or under-torquing.

Observe the specified torques when tightening control valve components. Excessive tightening torques lead to parts wearing out more quickly. Parts that are too loose may cause leakage.

- Observe the specified tightening torques (see the 'Tightening torques, lubricants and tools' chapter in the Appendix).
-

! NOTICE

Risk of valve damage due to the use of unsuitable tools.

- Only use tools approved by RINGO (see the 'Tightening torques, lubricants and tools' chapter in the Appendix).
-

5.3.1 Mounting the actuator onto the valve

! WARNING

Risk of personal injury due to the pre-loaded actuator springs.

Valves in combination with pneumatic actuators with preloaded springs are under tension.

- Before starting any work on the actuator, relieve the compression from the preloaded springs (see associated actuator documentation).
-

Depending on the version, RINGO control valves are either delivered with the actuator

Installation

already mounted on the valve or the valve and actuator are delivered separately. When delivered separately, the valve and actuator must be assembled together on site.

1. Before mounting the actuator, remove the temporary packing and replace it with the permanent packing (220) (see the 'Shipment and on-site transport' chapter > 'Temporary packing (220) in the bonnet (20)').
2. Before mounting the actuator, place the valve in the closed trim position.
3. Lift and position the actuator over the valve using the lifting equipment and accessories so that the actuator stems of the valve and actuator are exactly aligned.
4. Slowly lower the actuator, making sure that it can be connected to the valve without force.
5. To mount the actuator, proceed as described in the associated actuator documentation.

5.3.2 Installing the valve into the pipeline

NOTICE

Premature wear and leakage due to insufficient support or suspension.

→ Support or suspend the valve sufficiently at suitable points.

1. Close the shut-off valves in the pipeline at the inlet and outlet of the plant section while the valve is being installed.

2. Prepare the relevant section of the pipeline for installing the valve.
3. Remove the protective caps from the valve ports before installing the valve.
4. Lift the valve using suitable lifting equipment to the site of installation (see section 'Lifting the valve' in the 'Shipment and on-site transport' chapter). Observe the flow direction through the valve. The arrow on the valve indicates the direction of flow.
5. Make sure that the correct flange gaskets are used.
6. Bolt the pipe to the valve free of stress.
7. Attach a support or suspension on the valve, if necessary.

5.4 Testing the installed valve

⚠ DANGER

Risk of bursting due to incorrect opening of pressurized equipment or components.

Valves and pipelines are pressure equipment that may burst when handled incorrectly.

Flying projectile fragments or the release of process medium under pressure can cause serious injury or even death.

Before working on the control valve:

- Depressurize all plant sections affected and the valve (including the actuator). Release any stored energy.
 - Drain the process medium from the plant sections affected as well as from the valve.
-

⚠ WARNING**Risk of hearing loss or deafness due to loud noise.**

Noise emission (e.g. cavitation or flashing) may occur during operation caused by the process medium and the operating conditions. Additionally, a loud noise may briefly occur through the sudden venting of the pneumatic actuator or pneumatic valve accessories not fitted with noise-reducing fittings. Both can damage hearing.

- ➔ Wear hearing protection when working near the valve.

⚠ WARNING**Crush hazard arising from moving parts.**

The control valve has moving parts. The plug in the valve body is moved in a linear motion by the actuator. The actuator stems rotate. This can lead to crush injuries to hands or fingers if they are inserted into the valve.

- ➔ Do not insert hands or fingers into the valve body.
- ➔ Before working on the control valve, release any energy (in the actuator) which causes the actuator stem to move. This also applies to the actuator springs that are preloaded (see associated actuator documentation).
- ➔ Before working on the control valve, disconnect and lock the pneumatic air supply as well as the control signal if they are connected.
- ➔ Disconnect the supply voltage if it is connected before performing any work on the control valve.

- ➔ Do not impede the movement of the actuator drive and plug by inserting objects into them.

- ➔ Before attempting to unblock a plug after it has become blocked (e.g. due to seizing up after remaining in the same position for a long time), release any energy (in the actuator) which causes the actuator stem to move.

⚠ WARNING**Risk of personal injury due to exhaust air being vented from pneumatically operated components.**

When the valve is operated with a pneumatic actuator or pneumatic valve accessories, exhaust air may be vented from the actuator, for example, while the valve is operating in closed-loop control or when the valve opens or closes.

- ➔ Wear eye protection when working in close proximity to the control valve.

⚠ WARNING**Risk of personal injury due to the preloaded actuator springs.**

Valves in combination with pneumatic actuators with preloaded springs are under tension.

- ➔ Before starting any work on the actuator, relieve the compression from the preloaded springs (see associated actuator documentation).

ⓘ NOTICE

Risk of actuator damage due to operating the actuator while a high test pressure exists in the pipeline.

→ During hydrostatic testing of the pipeline, do not operate motorized control valves unless the test pressure of the pipeline is lower than the differential pressure specified for the actuator.

To test the valve functioning before start-up or putting back the valve into operation, perform the following tests:

5.4.1 Leakage

The plant operator is responsible for performing the leak test and selecting the test method. The leak test must comply with the requirements of the national and international standards that apply at the site of installation.

💡 Tip

Our after-sales service can support you to plan and perform a leak test for your plant.

1. Close the valve.
2. Slowly apply the test medium to the inlet space upstream of the valve. A sudden surge in pressure and resulting high flow velocities can damage the valve.
3. Open the valve.
4. Apply the required test pressure.

5. Check the valve for leakage to the atmosphere.
6. Depressurize the pipeline section and valve.
7. Rework any parts that leak and repeat the leak test. Read the following section "Adjusting the packing" for valves with a packing.

Adjusting the packing

ⓘ NOTICE

Impaired valve functioning due to increased friction as a result of the nut on the packing gland being tightened too far.

→ Make sure that the actuator stem (61) can still turn smoothly after the nuts has been tightened.

1. Tighten the nuts on the packing gland clockwise in a crisscross pattern until the packing seals the valve.
 2. Open and close the valve several times.
 3. Check the valve for leakage to the atmosphere.
 4. Repeat steps 1 and 2 until the packing completely seals the valve.
- If the packing still leaks, replace the packing (see the 'Servicing' chapter) or contact our after-sales service.

5.4.2 Rotary motion

The rotary motion of the actuator stem must be even and smooth.

- Apply the maximum and minimum control signals to check the end positions of the valve while observing the movement of the actuator stem.

5.4.3 Fail-safe position

The fail-safe position of the control valve upon air supply or control signal failure depends on the actuator used (see associated actuator documentation).

- Shut off the signal pressure line.
- Check whether the valve moves to the fail-safe position.

5.4.4 Pressure test

The plant operator is responsible for performing the pressure test.

**Tip**

Our after-sales service can support you to plan and perform a pressure test for your plant.

During the pressure test, make sure the following conditions are met:

- Move the plug forward to open the valve.
- Observe the maximum permissible pressure for both the valve and plant.

6 Start-up

The work described in this chapter is to be performed only by personnel appropriately qualified to carry out such tasks.

⚠ WARNING

Risk of burn injuries due to hot or cold components and pipeline.

Valve components and the pipeline may become very hot or cold. Risk of burn injuries.

- Allow components and pipelines to cool down or warm up to the ambient temperature.
- Wear protective clothing and safety gloves.

⚠ WARNING

Risk of hearing loss or deafness due to loud noise.

Noise emission (e.g. cavitation or flashing) may occur during operation caused by the process medium and the operating conditions. Additionally, a loud noise may briefly occur through the sudden venting of the pneumatic actuator or pneumatic valve accessories not fitted with noise-reducing fittings. Both can damage hearing.

- Wear hearing protection when working near the valve.

⚠ WARNING

Crush hazard arising from moving parts.

The control valve has moving parts. The plug in the valve body is moved in a linear motion by the actuator. The actuator stems ro-

tate. This can lead to crush injuries to hands or fingers if they are inserted into the valve.

- Do not insert hands or fingers into the valve body.
- Before working on the control valve, release any energy (in the actuator) which causes the actuator stem to move. This also applies to the actuator springs that are preloaded (see associated actuator documentation).
- Before working on the control valve, disconnect and lock the pneumatic air supply as well as the control signal if they are connected.
- Disconnect the supply voltage if it is connected before performing any work on the control valve.
- Do not impede the movement of the actuator drive and plug by inserting objects into them.
- Before attempting to unblock a plug after it has become blocked (e.g. due to seizing up after remaining in the same position for a long time), release any energy (in the actuator) which causes the actuator stem to move.

⚠ WARNING

Risk of personal injury due to exhaust air being vented from pneumatically operated components.

When the valve is operated with a pneumatic actuator or pneumatic valve accessories, exhaust air may be vented from the actuator, for example, while the valve is operating in closed-loop control or when the valve opens or closes.

Start-up

→ *Wear eye protection when working in close proximity to the control valve.*

Before start-up or putting the valve back into service, make sure the following conditions are met:

- The control valve is properly installed in the pipeline (see the 'Installation' chapter).
- The leak and function tests have been completed successfully (see section 'Testing the installed valve' in the 'Installation' chapter).
- The prevailing conditions in the plant section concerned meet the valve sizing requirements (see section 'Intended use' in the 'Safety instructions and measures' chapter).

Start-up/putting the device back into operation

1. Allow the valve to cool down or warm up to reach ambient temperature before start-up when the ambient temperature and process medium temperature differ greatly or the medium properties require such a measure.
2. Slowly open the shut-off valves in the pipeline. Slowly opening these valves prevents a sudden surge in pressure and high flow velocities which can damage the valve.
3. Check the valve to ensure it functions properly.

7 Operation

Immediately after completing start-up or putting the valve back into operation, the valve is ready for use.

⚠ WARNING

Risk of burn injuries due to hot or cold components and pipeline.

Valve components and the pipeline may become very hot or cold. Risk of burn injuries.

- Allow components and pipelines to cool down or warm up to the ambient temperature.
- Wear protective clothing and safety gloves.

⚠ WARNING

Risk of hearing loss or deafness due to loud noise.

Noise emission (e.g. cavitation or flashing) may occur during operation caused by the process medium and the operating conditions. Additionally, a loud noise may briefly occur through the sudden venting of the pneumatic actuator or pneumatic valve accessories not fitted with noise-reducing fittings. Both can damage hearing.

- Wear hearing protection when working near the valve.

⚠ WARNING

Crush hazard arising from moving parts.

The control valve has moving parts. The plug in the valve body is moved in a linear motion by the actuator. The actuator stems ro-

tate. This can lead to crush injuries to hands or fingers if they are inserted into the valve.

- Do not insert hands or fingers into the valve body.
- Before working on the control valve, release any energy (in the actuator) which causes the actuator stem to move. This also applies to the actuator springs that are preloaded (see associated actuator documentation).
- Before working on the control valve, disconnect and lock the pneumatic air supply as well as the control signal if they are connected.
- Disconnect the supply voltage if it is connected before performing any work on the control valve.
- Do not impede the movement of the actuator drive and plug by inserting objects into them.
- Before attempting to unblock a plug after it has become blocked (e.g. due to seizing up after remaining in the same position for a long time), release any energy (in the actuator) which causes the actuator stem to move.

⚠ WARNING

Risk of personal injury due to exhaust air being vented from pneumatically operated components.

When the valve is operated with a pneumatic actuator or pneumatic valve accessories, exhaust air may be vented from the actuator, for example, while the valve is operating in closed-loop control or when the valve opens or closes.

Operation

→ *Wear eye protection when working in close proximity to the control valve.*

7.1 Normal operation

The handwheel of valves with actuators fitted with a handwheel must be in the neutral position during normal operation.

7.2 Manual operation

Valves with actuators fitted with a handwheel can be manually closed or opened in the event of failure of the auxiliary energy supply.

8 Malfunctions

Read hazard statements, warnings and caution notes in the 'Safety instructions and measures' chapter.

8.1 Troubleshooting

Malfunction	Possible reasons	Recommended action
Actuator stem does not move on demand.	Actuator is blocked.	Check attachment. Put the control valve out of operation (see the 'Decommissioning' chapter) and remove the blockage. WARNING! A blocked actuator (e.g. due to seizing up after remaining in the same position for a long time) can suddenly start to rotate uncontrollably. Before trying to unblock the actuator stem, disconnect and lock the pneumatic air supply as well as the control signal. Before unblocking the actuator, release any stored energy in the actuator (e.g. spring compression). See associated actuator documentation.
	Electric actuators: no or incorrect supply voltage connected	Check the supply voltage and connections.
	Pneumatic actuators: diaphragm in the actuator defective	See associated actuator documentation.
	Pneumatic actuators: signal pressure too low	Check the signal pressure. Check the signal pressure line for leakage.
Actuator stem does not move through the whole angle of rotation.	Electric actuators: no or incorrect supply voltage connected	Check the supply voltage and connections.
	Pneumatic actuators: signal pressure too low	Check the signal pressure. Check the signal pressure line for leakage.
	Angle limitation active	See associated actuator documentation.
	Incorrect setting of valve accessories	Check the settings of the valve accessories.

Malfunctions

Malfunction	Possible reasons	Recommended action
Increased flow through closed valve (seat leakage)	Dirt or other foreign particles deposited between the cage and plug.	Shut off the section of the pipeline and flush the valve.
	Valve trim is worn out.	Replace cage and plug (see the 'Servicing' chapter) or contact our after-sales service.
The valve leaks to the atmosphere (fugitive emissions).	Flanged joint loose or gaskets worn out	Check the flanged joint. Replace the gasket at the flange joint. Replace the gaskets on the bonnet and actuator stem (see the 'Servicing' chapter).
	Version with packing: packing gland not tightened correctly	Tighten the nuts on the packing gland (see section 'Adjusting the packing' in the 'Installation' chapter> 'Testing the installed valve'). Contact our after-sales service when it continues to leak.

i Note

Contact our after-sales service for malfunctions not listed in the table.

8.2 Emergency action

Plant operators are responsible for emergency action to be taken in the plant.

In the event of a valve malfunction:

1. Close the shut-off valves upstream and downstream of the control valve to stop the process medium from flowing through the valve.
2. Perform troubleshooting (see Chapter 8.1).
3. Rectify those malfunctions that can be remedied following the information given in this document. Contact our after-sales service in all other cases.

Putting the device back into operation after a malfunction

See the 'Start-up' chapter.

9 Servicing

The work described in this chapter is to be performed only by personnel appropriately qualified to carry out such tasks.

The following documents are also required for servicing the valve:

- Mounting and operating instructions for the mounted actuator

⚠ DANGER

Risk of bursting due to incorrect opening of pressurized equipment or components.

Valves and pipelines are pressure equipment that may burst when handled incorrectly.

Flying projectile fragments or the release of process medium under pressure can cause serious injury or even death.

Before working on the control valve:

- Depressurize all plant sections affected and the valve (including the actuator). Release any stored energy.
 - Drain the process medium from the plant sections affected as well as from the valve.
-

⚠ WARNING

Risk of burn injuries due to hot or cold components and pipeline.

Valve components and the pipeline may become very hot or cold. Risk of burn injuries.

- Allow components and pipelines to cool down or warm up to the ambient temperature.
 - Wear protective clothing and safety gloves.
-

⚠ WARNING

Risk of hearing loss or deafness due to loud noise.

Noise emission (e.g. cavitation or flashing) may occur during operation caused by the process medium and the operating conditions. Additionally, a loud noise may briefly occur through the sudden venting of the pneumatic actuator or pneumatic valve accessories not fitted with noise-reducing fittings. Both can damage hearing.

- Wear hearing protection when working near the valve.
-

⚠ WARNING

Crush hazard arising from moving parts.

The control valve has moving parts. The plug in the valve body is moved in a linear motion by the actuator. The actuator stems rotate. This can lead to crush injuries to hands or fingers if they are inserted into the valve.

- Do not insert hands or fingers into the valve body.
 - Before working on the control valve, release any energy (in the actuator) which causes the actuator stem to move. This also applies to the actuator springs that are preloaded (see associated actuator documentation).
 - Before working on the control valve, disconnect and lock the pneumatic air supply as well as the control signal if they are connected.
 - Disconnect the supply voltage if it is connected before performing any work on the control valve.
-

- Do not impede the movement of the actuator drive and plug by inserting objects into them.
- Before attempting to unblock a plug after it has become blocked (e.g. due to seizing up after remaining in the same position for a long time), release any energy (in the actuator) which causes the actuator stem to move.

⚠ WARNING

Risk of personal injury due to exhaust air being vented from pneumatically operated components.

When the valve is operated with a pneumatic actuator or pneumatic valve accessories, exhaust air may be vented from the actuator, for example, while the valve is operating in closed-loop control or when the valve opens or closes.

- Wear eye protection when working in close proximity to the control valve.

⚠ WARNING

Risk of personal injury due to the preloaded actuator springs.

Valves in combination with pneumatic actuators with preloaded springs are under tension.

- Before starting any work on the actuator, relieve the compression from the preloaded springs (see associated actuator documentation).

⚠ WARNING

Risk of personal injury due to residual process medium in the valve.

While working on the valve, residual medium can flow out of the valve and, depending on its properties, cause personal injury, e.g. (chemical) burns.

- Wear protective clothing, safety gloves, respiratory protection and eye protection.

ⓘ NOTICE

Risk of damage to the valve trim parts through jolts or shocks

The valve can be fitted with a valve trim made of tungsten carbide to meet high requirements. Tungsten carbide has excellent hardness properties, but is extremely brittle. It can easily fracture under bending load.

- Avoid impacts to the valve.
- Avoid jolts or shocks (e.g. when transporting the valve).

ⓘ NOTICE

Risk of control valve damage due to over- or under-torquing.

Observe the specified torques when tightening control valve components. Excessive tightening torques lead to parts wearing out more quickly. Parts that are too loose may cause leakage.

- Observe the specified tightening torques (see the 'Tightening torques, lubricants and tools' chapter in the Appendix).

NOTICE

Risk of valve damage due to the use of unsuitable tools.

→ Only use tools approved by RINGO (see the 'Tightening torques, lubricants and tools' chapter in the Appendix).

NOTICE

Risk of valve damage due to the use of unsuitable lubricants.

→ Contact RINGO's After-sales Service Department for more information on suitable lubricants.

NOTICE

Risk of control valve damage due to unauthorized dismantling of the drive mechanism.

→ Do not dismantle the drive mechanism inside the valve, which converts the rotary motion of the actuator stem (61) into a linear motion of the plug stem (60).

i Note

The control valve was checked by RINGO before it left the factory.

- Certain test results certified by RINGO lose their validity when the valve is opened. Such testing includes seat leakage and leak tests.
- The product warranty becomes void if service or repair work not described in these instructions is performed without prior agreement by RINGO's after-sales service.

– Only use original spare parts by RINGO, which comply with the original specifications.

9.1 Periodic testing

Depending on the operating conditions, check the valve at certain intervals to prevent possible failure before it can occur. Plant operators are responsible for drawing up an inspection and test plan.

Tip

Our after-sales service can support you in drawing up an inspection and test plan for your plant.

→ A valve in service must be checked for leakage at least every three months.

Servicing

RINGO recommends the following inspections and tests:

Inspection and testing	Action to be taken in the event of a negative result:
Check the markings, labels and name-plates on the valve for their readability and completeness.	Immediately renew damaged, missing or incorrect name-plates or labels.
	Clean any inscriptions that are covered with dirt and are illegible.
Check the pipe connections and gaskets on the valve and actuator for leakage.	Checking flanged joints (tightening torques)
	Performing service work (see Chapter 9.4.1)
Check the valve's seat leakage.	Shut off the section of the pipeline and flush the valve to remove any dirt and/or deposited foreign particles between the cage and plug.
	Performing service work (see Chapter 9.4.2)
Check the valve for external damage that could impair the proper functioning of the control valve or even its safe operation.	Repair any damage immediately. If necessary, put the control valve out of operation (see the 'Decommissioning' chapter).
Check the valve accessories to ensure they are mounted properly.	Tighten the connections of the valve accessories.
Check to ensure that the actuator stems rotate smoothly.	<p>If the actuator stem is blocked, put the control valve out of operation (see the 'Decommissioning' chapter) and remove the blockage.</p> <p>WARNING! A blocked actuator (e.g. due to seizing up after remaining in the same position for a long time) can suddenly start to rotate uncontrollably.</p> <p>Before trying to unblock the actuator stem, disconnect and lock the pneumatic air supply as well as the control signal.</p> <p>Before unblocking the actuator, release any stored energy in the actuator (e.g. spring compression). See associated actuator documentation.</p>
If possible, check the valve's fail-safe position by briefly interrupting the air supply.	Put the control valve out of operation (see the 'Decommissioning' chapter). Identify the cause for the malfunction and rectify it (see the 'Troubleshooting' chapter).

9.2 Service work preparations

1. Lay out the necessary material and tools to have them ready for the service work.
2. Put the control valve out of operation (see the 'Decommissioning' chapter).
3. Place the valve in the closed trim position.
4. Remove the actuator from the valve. See associated actuator documentation.
5. The valve must be removed from the pipeline before performing the following service work (see the 'Removal' chapter).
 - Replacing the gaskets on the trim

The valve can remain in the pipeline for the following service work:

- Replacing the gaskets on the bonnet and actuator stem

9.3 Installing the valve after service work

1. Mount actuator. See associated actuator documentation and the 'Installation' chapter.
2. Adjust lower or upper signal bench range. See associated actuator documentation.
3. If the valve has been removed, re-install the valve into the pipeline (see the 'Installation' chapter).
4. Put the control valve back into operation (see the 'Start-up' chapter). Observe the requirements and conditions for start-up or putting the valve back into operation.

9.4 Service work

- ➔ Before performing any service work, preparations must be made to the control valve (see Chapter 9.2).
- ➔ After all service work is completed, check the control valve before putting it back into operation (see section 'Testing the installed valve' in the 'Installation' chapter).

9.4.1 Replacing the gaskets on the bonnet and actuator stem

Version without packing

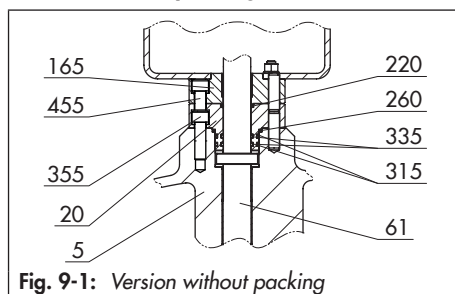

Fig. 9-1: Version without packing

1. Undo the bolted joint (391/392) on the yoke (625) and remove the nuts and bolts including washers (453) from the valve.
2. Undo the bolts (455) of the connecting flange (165) gradually in a crisscross pattern.
3. Remove the connecting flange (165) from the valve.
4. Undo the bolts (355) of the bonnet (20) gradually in a crisscross pattern.

Servicing

- Remove the bonnet (20) from the valve body (5).
- Remove all gaskets (220, 260, 2x 315 and 2x 335) of the bonnet (20) and replace with new ones. During this process, clean the contact surfaces and apply lubricant to the new gaskets.
- Replace the bonnet (20) back on the valve body (5).
- Apply lubricant to the threads of the bolts (355).
- Gradually tighten the bolts (355) in a crisscross pattern. Apply the target torque over several rounds. Observe the specified tightening torques and sequence (see the 'Tightening torques, lubricants and tools' chapter in the Appendix).
- Replace the connecting flange (165) back on the bonnet (20).
- Apply lubricant to the threads of the bolts (455).
- Gradually tighten the bolts (455) in a crisscross pattern. Apply the target torque over several rounds. Observe the specified tightening torques and sequence (see the 'Tightening torques, lubricants and tools' chapter in the Appendix).
- Reinsert and tighten the nuts and bolts including washers (453) for the bolted joint (391/392) to remount the yoke (625) on the valve. Apply lubricant to the threads beforehand.

Version with packing

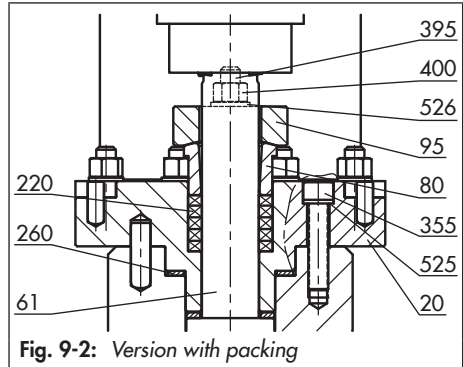

- Undo the bolted joint (391/392) on the yoke (625) and remove the nuts and bolts including washers (453) from the valve.
- Undo the bolted joint (395/400) on the packing gland (95).
- Remove the packing gland (95) and the stuffing box (80).
- Undo the bolts (355) of the bonnet (20) gradually in a crisscross pattern.
- Remove the bonnet (20) from the valve body (5).
- Remove the gasket (260) and replace with a new one. During this process, clean the contact surfaces and apply lubricant to the new gasket.
- Pull all the packing parts (220) out of the packing chamber of the bonnet (20) using a suitable tool.
- Clean the packing chamber thoroughly.
- Replace the bonnet (20) back on the valve body (5).

10. Apply lubricant to the threads of the bolts (355).
11. Gradually tighten the bolts (355) in a crisscross pattern. Apply the target torque over several rounds. Observe the specified tightening torques and sequence (see the 'Tightening torques, lubricants and tools' chapter in the Appendix).
12. Apply a suitable lubricant to the actuator stem (61).
13. Apply lubricant to the new packing rings.
14. Carefully slide the new packing rings one by one over the actuator stem (61) into the packing chamber of the bonnet (20). Push each ring down with a packing tool (special tool, see the 'Tightening torques, lubricants and tools' chapter in the Appendix). Each packing ring must be inserted with its butt joint offset by 120 ° to the previous ring (see Fig. 9-2 for the installed state).
15. Slide the stuffing box (80) over the actuator stem (61) onto the packing (220).
16. Place the packing gland (95) with the flat side facing upwards onto the stud bolts (395).
17. Thread the nuts (400) of the packing gland (95) onto the stud bolts (395) and finger tighten them clockwise in a crisscross pattern.
18. Reinsert and tighten the nuts and bolts including washers (453) for the bolted joint (391/392) to remount the yoke

(625) on the valve. Apply lubricant to the threads beforehand.

9.4.2 Replacing the gaskets on the trim

! NOTICE

Risk of control valve damage due to incorrect servicing.

→ Only replace the trim gaskets with new ones if the trim material is not tungsten carbide.

→ To replace the gaskets in a trim made of tungsten carbide, contact our after-sales service.

See Fig. 9-3

1. Place the valve resting on the inlet flange and with the valve outlet facing upwards.
2. Remove the welding points on the central nut (1632) at the valve outlet (see Fig. 9-4) and use a suitable tool (socket) to unscrew and remove the nut.
3. Place a special tool (see the 'Tightening torques, lubricants and tools' chapter in the Appendix) on the retaining ring (171). The retaining ring (171) is screwed to the valve body (5).
4. Use the special tool to unscrew the retaining ring (171) out of the valve body (5).
5. Pull the seat ring (70) out of the valve body (5). To do this, use the extraction threaded holes on the front face of the seat ring (70).

Servicing

6. Remove the flat plug (15) from the plug stem (60). To do this, use the threaded holes on the front face of the flat plug (15).
7. Pull the cage (26) out of the valve body (5). To do this, use the extraction threaded holes on the front face of the cage (26).
8. Replace the gaskets (254, 1773A and 1773B) on the cage (26) with new ones. Observe the proper sequence and alignment of the gaskets (see detailed view in Fig. 9-3). During this process, clean the contact surfaces and apply lubricant to the new gaskets.
9. Reinsert the cage (26) in the upright position back into the valve body (5) and place it onto the balancing cylinder (931).
10. Reinsert the flat plug (15) back into the valve body and place it onto the plug stem (60).
11. Replace the gasket (325) of the seat ring (70) with a new one. During this process, clean the contact surfaces and apply lubricant to the new gasket.

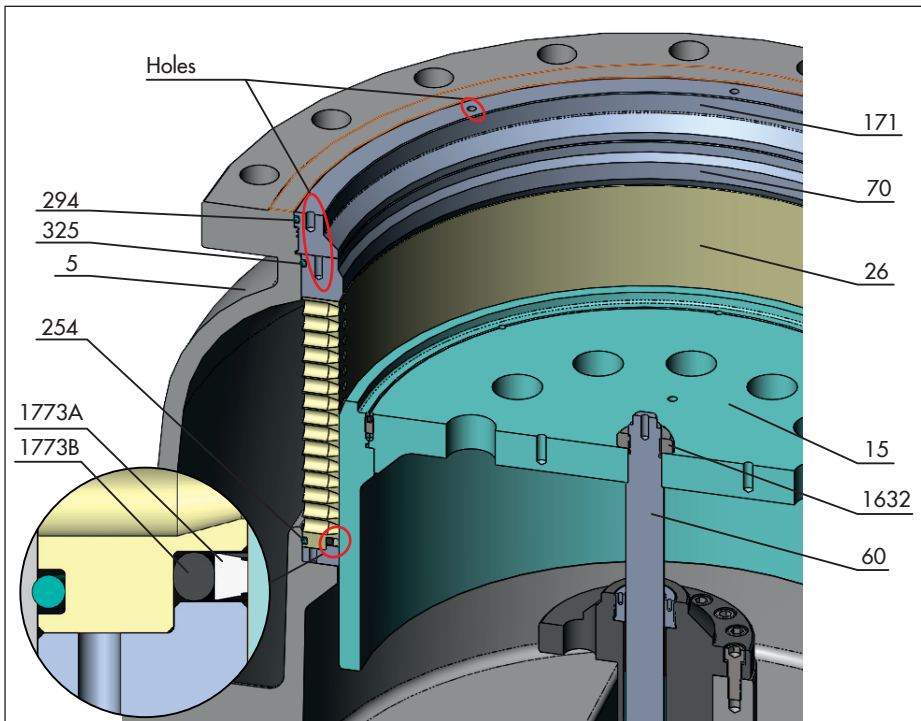

Fig. 9-3: Trim

12. Reinsert the seat ring (70) into the valve body (5).
13. Replace the gasket (294) of the retaining ring (171) with a new one. During this process, clean the contact surfaces and apply lubricant to the new gasket.
14. Use the special tool to screw the retaining ring (171) back into the valve body (5). Only screw it in to the point where the outside surface of the retaining ring is flush with the flange face of the valve body.
15. Screw the nut (1632) back onto the plug stem (60) and tighten it.
16. Fix the nut (1632) in place with two welding points to prevent it from coming undone unintentionally (see Fig. 9-4).

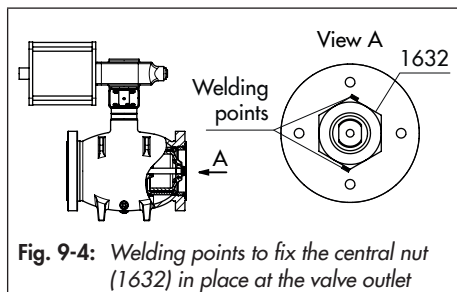

Fig. 9-4: *Welding points to fix the central nut (1632) in place at the valve outlet*

9.5 Ordering spare parts and operating supplies

Contact your nearest SAMSON subsidiary or RINGO's after-sales service for information on spare parts, lubricants and tools.

Spare parts

See Appendix for details on spare parts.

Lubricant

Contact RINGO's After-sales Service Department for more information on suitable lubricants.

Tools

See the 'Tightening torques, lubricants and tools' chapter in the Appendix of these instructions for details on suitable tools.

10 Decommissioning

The work described in this chapter is to be performed only by personnel appropriately qualified to carry out such tasks.

⚠ DANGER

Risk of bursting due to incorrect opening of pressurized equipment or components.

Valves and pipelines are pressure equipment that may burst when handled incorrectly. Flying projectile fragments or the release of process medium under pressure can cause serious injury or even death.

Before working on the control valve:

- Depressurize all plant sections affected and the valve (including the actuator). Release any stored energy.
- Drain the process medium from the plant sections affected as well as from the valve.

⚠ WARNING

Risk of burn injuries due to hot or cold components and pipeline.

Valve components and the pipeline may become very hot or cold. Risk of burn injuries.

- Allow components and pipelines to cool down or warm up to the ambient temperature.
- Wear protective clothing and safety gloves.

⚠ WARNING

Risk of hearing loss or deafness due to loud noise.

Noise emission (e.g. cavitation or flashing) may occur during operation caused by the process medium and the operating conditions. Additionally, a loud noise may briefly occur through the sudden venting of the pneumatic actuator or pneumatic valve accessories not fitted with noise-reducing fittings. Both can damage hearing.

- Wear hearing protection when working near the valve.

⚠ WARNING

Crush hazard arising from moving parts.

The control valve has moving parts. The plug in the valve body is moved in a linear motion by the actuator. The actuator stems rotate. This can lead to crush injuries to hands or fingers if they are inserted into the valve.

- Do not insert hands or fingers into the valve body.
- Before working on the control valve, release any energy (in the actuator) which causes the actuator stem to move. This also applies to the actuator springs that are preloaded (see associated actuator documentation).
- Before working on the control valve, disconnect and lock the pneumatic air supply as well as the control signal if they are connected.
- Disconnect the supply voltage if it is connected before performing any work on the control valve.

Decommissioning

- Do not impede the movement of the actuator drive and plug by inserting objects into them.
 - Before attempting to unblock a plug after it has become blocked (e.g. due to seizing up after remaining in the same position for a long time), release any energy (in the actuator) which causes the actuator stem to move.
-

WARNING

Risk of personal injury due to exhaust air being vented from pneumatically operated components.

When the valve is operated with a pneumatic actuator or pneumatic valve accessories, exhaust air may be vented from the actuator, for example, while the valve is operating in closed-loop control or when the valve opens or closes.

- Wear eye protection when working in close proximity to the control valve.
-

WARNING

Risk of personal injury due to residual process medium in the valve.

While working on the valve, residual medium can flow out of the valve and, depending on its properties, cause personal injury, e.g. (chemical) burns.

- Wear protective clothing, safety gloves, respiratory protection and eye protection.
-

To decommission the control valve for service work or to remove it from the pipeline, proceed as follows:

1. Close the shut-off valves upstream and downstream of the control valve to stop the process medium from flowing through the valve.
2. Completely drain the pipelines and valve.
3. Disconnect and lock the pneumatic air supply and/or electrical power to depressurize the control valve.
4. Release any stored energy.
5. If necessary, allow the pipeline and valve components to cool down or warm up to the ambient temperature.

11 Removal

The work described in this chapter is to be performed only by personnel appropriately qualified to carry out such tasks.

⚠ WARNING

Risk of burn injuries due to hot or cold components and pipeline.

Valve components and the pipeline may become very hot or cold. Risk of burn injuries.

- Allow components and pipelines to cool down or warm up to the ambient temperature.
- Wear protective clothing and safety gloves.

⚠ WARNING

Crush hazard arising from moving parts.

The control valve has moving parts. The plug in the valve body is moved in a linear motion by the actuator. The actuator stems rotate. This can lead to crush injuries to hands or fingers if they are inserted into the valve.

- Do not insert hands or fingers into the valve body.
- Before working on the control valve, release any energy (in the actuator) which causes the actuator stem to move. This also applies to the actuator springs that are preloaded (see associated actuator documentation).
- Before working on the control valve, disconnect and lock the pneumatic air supply as well as the control signal if they are connected.

- Disconnect the supply voltage if it is connected before performing any work on the control valve.
- Do not impede the movement of the actuator drive and plug by inserting objects into them.
- Before attempting to unblock a plug after it has become blocked (e.g. due to seizing up after remaining in the same position for a long time), release any energy (in the actuator) which causes the actuator stem to move.

⚠ WARNING

Risk of personal injury due to residual process medium in the valve.

While working on the valve, residual medium can flow out of the valve and, depending on its properties, cause personal injury, e.g. (chemical) burns.

- Wear protective clothing, safety gloves, respiratory protection and eye protection.

⚠ WARNING

Risk of personal injury due to the preloaded actuator springs.

Valves in combination with pneumatic actuators with preloaded springs are under tension.

- Before starting any work on the actuator, relieve the compression from the preloaded springs (see associated actuator documentation).

Removal

Before removing the valve, make sure the following conditions are met:

- The control valve is put out of operation (see the 'Decommissioning' chapter).

11.1 Removing the valve from the pipeline

1. Support the valve to hold it in place when separated from the pipeline (see the 'Shipment and on-site transport' chapter).
2. Unbolt the flanged joint.
3. Remove the valve from the pipeline (see the 'Shipment and on-site transport' chapter).

11.2 Removing the actuator from the valve

See associated actuator documentation.

12 Repairs

If the valve does not function properly according to how it was originally sized or does not function at all, it is defective and must be repaired or exchanged.

! NOTICE

Risk of valve damage due to incorrect service or repair work.

- *Do not perform any repair work on your own.*
 - *Contact RINGO's after-sales service for repair work.*
-

The declaration form can be downloaded from our website at ► www.samsongroup.com > Service > After-sales Service > Returning goods

12.1 Returning devices to RINGO

Defective devices can be returned to RINGO for repair.

Before returning devices, contact RINGO's after-sales service **first** to clarify the procedure to return devices. The procedure to be agreed upon depends on the version and application of the control valve to be returned. On contacting the after-sales service, provide the following details:

- Type
- Serial number
- Original order

The device must be decontaminated before returning it. Fill in and sign the Declaration on Decontamination. Send it in advance to the after-sales service and attach it to the shipment.

13 Disposal

- Observe local, national and international refuse regulations.
- Do not dispose of components, lubricants and hazardous substances together with your household waste.

14 Certificates

These declarations are included on the next pages:

- Declaration of conformity in compliance with Pressure Equipment Directive 2014/68/EU:
 - Country of origin: Spain,
see page 14-2 to page 14-11

The declaration in compliance with Machinery Directive 2006/42/EC is available as a separate document for specific orders.

The certificates shown were up to date at the time of publishing.

Other optional certificates are available on request.

EU CERTIFICATE OF CONFORMITY

In accordance with the requirements of the Pressure Equipment Directive 2014/68/EU

This is to certify that the Quality Management System of:

RINGO VALVULAS, S.L. (SAMSON – RINGO)
Pol. Industrial Empresarium
C/ Romero nº 6 y 8
50720 – La Cartuja (ZARAGOZA) - Spain

has been assessed against the requirements of Annex III, **Module H** of the Pressure Equipment Directive 2014/68/EU and conforms to the requirements for the products shown below:

Design and manufacturing of pressure accessories. Gate, globe, check, ball, butterfly, plug, diaphragm, control, axial and special valves for industrial applications. (Pressure, materials and dimensions detailed in certificate schedule)

Approval is subject to the continued maintenance of the quality system in accordance with the requirements of the above Directive for the products listed on the attached schedule.

Authorisation is hereby given to use the LRQA Inspection Iberia, S.A Notified Body Identification Number in accordance with the requirements of the specified Directive in relation to the products as identified above.

Certificate No: 0094/PED/MAD/0132 ENG

Original Approval: 20 December 2020

Current Certificate: 22 May 2023

Certificate Expiry: 29 November 2024

LRQA Inspection Iberia, S.A Notified Body 0094

Cristel López, LRQA Decision Maker



LRQA Inspection Iberia, S.A. is a company registered in the R. M. de Madrid, in Volume 5218 general, 4358, of Section Sec. 3.ª of the Companies Book, folio 133 sheet nº 41397, inscription, 1.ª C.I.F. - A28591287 - Registered office C/Princesa 29, 15. 28008 Madrid - A subsidiary of LRQA Group Limited.

LRQA Group Limited, its affiliates and subsidiaries and their respective officers, employees or agents are, individually and collectively, referred to in this clause as 'LRQA'. LRQA assumes no responsibility and shall not be liable to any person for any loss, damage or expense caused by reliance on the information or advice in this document or howsoever provided, unless that person has signed a contract with the relevant LRQA entity for the provision of this information or advice and in that case any responsibility or liability is exclusively on the terms and conditions set out in that contract.

0094-PED-mod-H.From_R4-230March23_ENG

**EU CERTIFICATE SCHEDULE
0094/PED/MAD/0132 ENG**

In accordance with the requirements of the Pressure Equipment Directive 2014/68/EU.

Product (s)	Model	Design Standard/ Code	Size Range	Rating Range	Materials
					A216 (WCB/WCC), A182 (Gr.: F1/F5/F5a/F9/F11/F22/F44/F51/F53/F91/F304/F304L/F316/F316H/F316L/F321/F347/F347H), A240 316, A217 (C5/C12A/WC1/WC6/WC9), A350 (LF2/LF3), A351 (CD4MCu/CF3/CF3M/CF8/CF8C/CF8M/CK3MCuN), A352 (LC1/LC2/LC3/LCB/LCC), A453 Gr. 660B, A479 (T304/T304L/T316/T316L/T321), A494 (CW6MC/M35-1), B564 (N04400/N06625)
Globe valve	<p>Straight pattern</p> <p>Y pattern</p> <p>Angle pattern</p> <p>Stop check</p>	<p>ANSI B16.34</p> <p>API 6A</p> <p>API 602</p> <p>EN 12516</p> <p>BS 1873</p>	<p>Up to:</p> <p>48"</p> <p>DN1200</p>	<p>Up to:</p> <p>4500 #</p> <p>20.000 psi</p> <p>PN400</p>	<p>1.0426 (EN 10222-2), 1.0460 (EN 10273), 1.0619 (EN 10213), 1.0625 (EN 10213), 1.0426 (EN 10222-2), 1.0460 (EN 10273), 1.0619 (EN 10213), 1.0625 (EN 1.0426 (EN 10222-2), 1.0460 (EN 10273), 1.0619 (EN 10213), 1.0625 (EN 10213), 1.4308 (EN 10213), 1.4401 (EN 10222-5), 1.4404 (EN 10222-5), 1.4408 (EN 10213), 1.4409 (EN 10213), 1.4541 (EN 10222-5), 1.4550 (EN 10222-5), 1.4552 (EN 10213), 1.4571 (EN 10222-5), 1.4581 (EN 10213), 1.5415 (EN 10222-2), 1.6368 (EN 10216-2), 1.7335 (EN 10222-2), A105, A194 Gr. 6 T410, A216 (WCB/WCC), A182 (Gr.: F1/F5/F5a/F9/F11/F22/F44/F51/F53/F91/F304/F304L/F316/F316H/F316L/F321/F347/F347H), A240 316, A217 (C5/C12A/WC1/WC6/WC9), A350 (LF2/LF3), A351 (CD4MCu/CF3/CF3M/CF8/CF8C/CF8M/CK3MCuN), A352 (LC1/LC2/LC3/LCB/LCC), A453 Gr. 660B, A479 (T304/T304L/T316/T316L/T321), A494 (CW6MC/M35-1), B564 (N04400/N06625)</p>



LRQA Inspection Iberia, S.A. is a company registered in the R. M. de Madrid, in Volume 5218 general, 4358, of Section Sec. 1ª of the Companies Book, folio 133 sheet nº 41397, inscription. 1ª C.I.F. A28591287 - Registered office C/Princesa 29, 1ª. 28008 Madrid. A subsidiary of LRQA Group Limited.

LRQA Group Limited, its affiliates and subsidiaries and their respective officers, employees or agents are, individually and collectively, referred to in this clause as 'LRQA'. LRQA assumes no responsibility and shall not be liable to any person for any loss, damage or expense caused by reliance on the information or advice in this document or howsoever provided, unless that person has signed a contract with the relevant LRQA entity for the provision of this information or advice and in that case any responsibility or liability is exclusively on the terms and conditions set out in that contract.

EU CERTIFICATE SCHEDULE 0094/PED/MAD/0132 ENG

In accordance with the requirements of the Pressure Equipment
Directive 2014/68/EU.

Product (s)	Model	Design Standard/ Code	Size Range	Rating Range	Materials
Globe valve 3588	<p style="text-align: center;">Straight pattern</p> <p style="text-align: center;">Y pattern</p> <p style="text-align: center;">Angle pattern</p> <p style="text-align: center;">Stop check</p>	<p style="text-align: center;">ANSI B16.34</p> <p style="text-align: center;">API 6A</p> <p style="text-align: center;">API 602</p> <p style="text-align: center;">EN 12516</p> <p style="text-align: center;">BS 1873</p>	<p style="text-align: center;">Up to:</p> <p style="text-align: center;">12"</p> <p style="text-align: center;">DN300</p>	<p style="text-align: center;">Up to:</p> <p style="text-align: center;">1500 #</p> <p style="text-align: center;">PN250</p>	<p>1.0426 (EN 10222-2), 1.0460 (EN 10273), 1.0619 (EN 10213), 1.0625 (EN 10213), 1.4308 (EN 10213), 1.4401 (EN 10222-5), 1.4404 (EN 10222-5), 1.4408 (EN 10213), 1.4409 (EN 10213), 1.4541 (EN 10222-5), 1.4550 (EN 10222-5), 1.4552 (EN 10213), 1.4571 (EN 10222-5), 1.4581 (EN 10213), 1.5415 (EN 10222-2), 1.6368 (EN 10216-2), 1.7335 (EN 10222-2), A105, A194 Gr. 6 T410, A216 (WCB/WCC), A182 (Gr.: F1/F5/F5a/F9/F11/F22/F44/F51/F53/F91/F304/F304L/F316/F316H/F316L/F321/F347/F347H), A240 316, A217 (C5/C12A/WC1/WC6/WC9), A350 (LF2/LF3), A351 (CD4MCu/CF3/CF3M/CF8/CF8C/CF8M/CK3MCuN), A352 (LC1/LC2/LC3/LCB/LCC), A453 Gr. 660B, A479 (T304/T304L/T316/T316L/T321), A494 (CW6MC/M35-1), B564 (N04400/N06625)</p>
Check valve	<p style="text-align: center;">Piston</p> <p style="text-align: center;">Swing</p> <p style="text-align: center;">Dual plate</p> <p style="text-align: center;">Tilting Disc</p>	<p style="text-align: center;">ANSI B16.34</p> <p style="text-align: center;">API 6D</p> <p style="text-align: center;">API 6DSS</p> <p style="text-align: center;">API 6A</p> <p style="text-align: center;">API 602</p> <p style="text-align: center;">EN 12516</p> <p style="text-align: center;">BS 1868</p>	<p style="text-align: center;">Up to:</p> <p style="text-align: center;">64"</p> <p style="text-align: center;">DN1600</p>	<p style="text-align: center;">Up to:</p> <p style="text-align: center;">4500 #</p> <p style="text-align: center;">20.000 psi</p> <p style="text-align: center;">PN400</p>	<p>1.0426 (EN 10222-2), 1.0460 (EN 10273), 1.0619 (EN 10213), 1.0625 (EN 10213), 1.0426 (EN 10222-2), 1.0460 (EN 10273), 1.0619 (EN 10213), 1.0625 (EN 10273), 1.0619 (EN 10213), 1.0625 (EN 10222-2), 1.0460 (EN 10273), 1.0619 (EN 10213), 1.0625 (EN 10213), 1.4308 (EN 10213), 1.4401 (EN 10222-5), 1.4404 (EN 10222-5), 1.4408 (EN 10213), 1.4409 (EN 10213), 1.4541 (EN 10222-5), 1.4550 (EN 10222-5), 1.4552 (EN 10213), 1.4571 (EN 10222-5), 1.4581 (EN 10213), 1.5415 (EN 10222-2), 1.6368 (EN 10216-2), 1.7335 (EN 10222-2), A105, A194 Gr. 6 T410, A216 (WCB/WCC), A182 (Gr.: F1/F5/F5a/F9/F11/F22/F44/F51/F53/F91/F304/F304L/F316/F316H/F316L/F3</p>



LRQA Inspection Iberia, S.A. is a company registered in the R. M. de Madrid, in Volume 5238 general, 4356, of Section Sec. 3 of the Companies Book, folio 133 sheet nº 41397, inscription. 1.º
C.I.F. - A28581287 - Registered office C/Princesa 29, 1º, 28008 Madrid. A subsidiary of LRQA Group Limited.

LRQA Group Limited, its affiliates and subsidiaries and their respective officers, employees or agents are, individually and collectively, referred to in this clause as 'LRQA'. LRQA assumes no responsibility and shall not be liable to any person for any loss, damage or expense caused by reliance on the information or advice in this document or howsoever provided, unless that person has signed a contract with the relevant LRQA entity for the provision of this information or advice and in that case any responsibility or liability is exclusively on the terms and conditions set out in that contract.

**EU CERTIFICATE SCHEDULE
0094/PED/MAD/0132 ENG**

In accordance with the requirements of the Pressure Equipment Directive 2014/68/EU.

Product (s)	Model	Design Standard/ Code	Size Range	Rating Range	Materials
					21/F347/F347H), A240 316, A217 (C5/C12A/WC1/WC6/WC9), A350 (LF2/LF3), A351 (CD4MCu/CF3/CF3M/CF8/CF8C/CF8M/CK3MCuN), A352 (LC1/LC2/LC3/LCB/LCC), A453 Gr. 660B, A479 (T304/T304L/T316/T316L/T321), A494 (CW6MC/M35-1), B564 (N04400/N06625)
Butterfly valve	Concentric Double Eccentric Triple eccentric	ANSI B16.34 API 609 MSS SP-67 BS 3952 EN 12516 AWWA C-504	Up to: 72" DN1800	Up to: 600 # PN100	1.0426 (EN 10222-2), 1.0460 (EN 10273), 1.0619 (EN 10213), 1.0625 (EN 10213), 1.0426 (EN 10222-2), 1.0460 (EN 10273), 1.0619 (EN 10213), 1.0625 (EN 1.0426 (EN 10222-2), 1.0460 (EN 10273), 1.0619 (EN 10213), 1.0625 (EN 10213), 1.4308 (EN 10213), 1.4401 (EN 10222-5), 1.4404 (EN 10222-5), 1.4408 (EN 10213), 1.4409 (EN 10213), 1.4541 (EN 10222-5), 1.4550 (EN 10222-5), 1.4552 (EN 10213), 1.4571 (EN 10222-5), 1.4581 (EN 10213), 1.5415 (EN 10222-2), 1.6368 (EN 10216-2), 1.7335 (EN 10222-2), A105, A194 Gr. 6 T410, A216 (WCB/WCC), A182 (Gr.: F1/F5/F5a/F9/F11/F22/F44/F51/F53/F 91/F304/F304L/F316/F316H/F316L/F3 21/F347/F347H), A240 316, A217 (C5/C12A/WC1/WC6/WC9), A350 (LF2/LF3), A351 (CD4MCu/CF3/CF3M/CF8/CF8C/CF8M/CK3MCuN), A352 (LC1/LC2/LC3/LCB/LCC), A453 Gr. 660B, A479 (T304/T304L/T316/T316L/T321), A494 (CW6MC/M35-1), B564 (N04400/N06625)
Diaphragm valve		ANSI B16.34 API 6A API 602 EN 12516	Up to: 6" DN150	Up to: 300 # PN63	1.0426 (EN 10222-2), 1.0460 (EN 10273), 1.0619 (EN 10213), 1.0625 (EN 10213), 1.0426 (EN 10222-2), 1.0460 (EN 10273), 1.0619 (EN 10213), 1.0625



LRQA Inspection Iberia, S.A. is a company registered in the R. M. de Madrid, in Volume 5218 general, 4358, of Section Sec. 1ª of the Companies Book, folio 133 sheet nº 41397, inscription. 1ª C.I.F. - A28591287 - Registered office C/Princesa 29, 1ª - 28008 Madrid. A subsidiary of LRQA Group Limited.

LRQA Group Limited, its affiliates and subsidiaries and their respective officers, employees or agents are, individually and collectively, referred to in this clause as 'LRQA'. LRQA assumes no responsibility and shall not be liable to any person for any loss, damage or expense caused by reliance on the information or advice in this document or howsoever provided, unless that person has signed a contract with the relevant LRQA entity for the provision of this information or advice and in that case any responsibility or liability is exclusively on the terms and conditions set out in that contract.

EU CERTIFICATE SCHEDULE 0094/PED/MAD/0132 ENG

In accordance with the requirements of the Pressure Equipment
Directive 2014/68/EU.

Product (s)	Model	Design Standard/ Code	Size Range	Rating Range	Materials
					(EN 1.0426 (EN 10222-2), 1.0460 (EN 10273), 1.0619 (EN 10213), 1.0625 (EN 10213), 1.4308 (EN 10213), 1.4401 (EN 10222-5), 1.4404 (EN 10222-5), 1.4408 (EN 10213), 1.4409 (EN 10213), 1.4541 (EN 10222-5), 1.4550 (EN 10222-5), 1.4552 (EN 10213), 1.4571 (EN 10222-5), 1.4581 (EN 10213), 1.5415 (EN 10222-2), 1.6368 (EN 10216-2), 1.7335 (EN 10222-2), A105, A194 Gr. 6 T410, A216 (WCB/WCC), A182 (Gr.: F1/F5/F5a/F9/F11/F22/F44/F51/F53/F91/F304/F304L/F316/F316H/F316L/F321/F347/F347H), A240 316, A217 (C5/C12A/WC1/WC6/WC9), A350 (LF2/LF3), A351 (CD4MCu/CF3/CF3M/CF8/CF8C/CF8M/CK3MCuN), A352 (LC1/LC2/LC3/LCB/LCC), A453 Gr. 660B, A479 (T304/T304L/T316/T316L/T321), A494 (CW6MC/M35-1), B564 (N04400/N06625)
Axial valve 3599		ANSI B16.34 API 6A API 6DSS EN 12516	Up to: 60" DN1500	Up to: 2500 # 20.000 psi PN320	1.0426 (EN 10222-2), 1.0460 (EN 10273), 1.0619 (EN 10213), 1.0625 (EN 10213), 1.0426 (EN 10222-2), 1.0460 (EN 10273), 1.0619 (EN 10213), 1.0625 (EN 10222-5), 1.4404 (EN 10222-5), 1.4408 (EN 10213), 1.4541 (EN 10213), 1.4550 (EN 10222-5), 1.4552 (EN 10213), 1.4571 (EN 10222-5), 1.4581 (EN 10213), 1.5415 (EN 10222-2), 1.6368 (EN 10216-2), 1.7335 (EN 10222-2), A105, A194 Gr. 6 T410, A216 (WCB/WCC), A182 (Gr.: F1/F5/F5a/F9/F11/F22/F44/F51/F53/F91/F304/F304L/F316/F316H/F316L/F321/F347/F347H), A240 316, A217



LRQA Inspection Iberia, S.A. is a company registered in the R. M. de Madrid, in Volume 5238 general, 4356, of Section Sec. 3 of the Companies Book, folio 133 sheet nº 41397, inscription, 1.ª C.I.F. - A28581287 - Registered office C/Princesa 29, 15, 28008 Madrid. A subsidiary of LRQA Group Limited.

LRQA Group Limited, its affiliates and subsidiaries and their respective officers, employees or agents are, individually and collectively, referred to in this clause as 'LRQA'. LRQA assumes no responsibility and shall not be liable to any person for any loss, damage or expense caused by reliance on the information or advice in this document or howsoever provided, unless that person has signed a contract with the relevant LRQA entity for the provision of this information or advice and in that case any responsibility or liability is exclusively on the terms and conditions set out in that contract.

**EU CERTIFICATE SCHEDULE
0094/PED/MAD/0132 ENG**

In accordance with the requirements of the Pressure Equipment
Directive 2014/68/EU.

Product (s)	Model	Design Standard/ Code	Size Range	Rating Range	Materials
					(C5/C12A/WC1/WC6/WC9), A350 (LF2/LF3), A351 (CD4MCu/CF3/CF3M/CF8/CF8C/CF8M/CK3MCuN), A352 (LC1/LC2/LC3/LCB/LCC), A453 Gr. 660B, A479 (T304/T304L/T316/T316L/T321), A494 (CW6MC/M35-1), B564 (N04400/N06625)
Control valve 3595	Straight pattern Y pattern Angle pattern 3-way Bellows seal	ANSI B16.34 API 6A EN 12516	Up to: 48" DN1200	Up to: 4500 # 20.000 psi PN400	1.0426 (EN 10222-2), 1.0460 (EN 10273), 1.0619 (EN 10213), 1.0625 (EN 10213), 1.0426 (EN 10222-2), 1.0460 (EN 10273), 1.0619 (EN 10213), 1.0625 (EN 1.0426 (EN 10222-2), 1.0460 (EN 10273), 1.0619 (EN 10213), 1.0625 (EN 10213), 1.4308 (EN 10213), 1.4401 (EN 10222-5), 1.4404 (EN 10222-5), 1.4408 (EN 10213), 1.4409 (EN 10213), 1.4541 (EN 10222-5), 1.4550 (EN 10222-5), 1.4552 (EN 10213), 1.4571 (EN 10222-5), 1.4581 (EN 10213), 1.5415 (EN 10222-2), 1.6368 (EN 10216-2), 1.7335 (EN 10222-2), A105, A194 Gr. 6 T410, A216 (WCB/WCC), A182 (Gr.: F1/F5/F5a/F9/F11/F22/F44/F51/F53/F91/F304/F304L/F316/F316H/F316L/F321/F347/F347H), A240 316, A217 (C5/C12A/WC1/WC6/WC9), A350 (LF2/LF3), A351 (CD4MCu/CF3/CF3M/CF8/CF8C/CF8M/CK3MCuN), A352 (LC1/LC2/LC3/LCB/LCC), A453 Gr. 660B, A479 (T304/T304L/T316/T316L/T321), A494 (CW6MC/M35-1), B564 (N04400/N06625)
Control valve 3251-E	Straight pattern Y pattern Angle pattern	ANSI B16.34 API 6A EN 12516	Up to: 36" DN900	Up to: 4500 # 20.000 psi	1.0426 (EN 10222-2), 1.0460 (EN 10273), 1.0619 (EN 10213), 1.0625 (EN 10213), 1.0426 (EN 10222-2), 1.0460 (EN 10273), 1.0619 (EN 10213), 1.0625 (EN 1.0426 (EN 10222-2), 1.0460 (EN 10273), 1.0619 (EN 10213), 1.0625 (EN 10213), 1.4308 (EN 10213), 1.4401 (EN 10222-5), 1.4404 (EN 10222-5), 1.4408 (EN 10213), 1.4409 (EN 10213), 1.4541 (EN 10222-5), 1.4550 (EN 10222-5), 1.4552 (EN 10213), 1.4571 (EN 10222-5), 1.4581 (EN 10213), 1.5415 (EN 10222-2), 1.6368 (EN 10216-2), 1.7335 (EN 10222-2), A105, A194 Gr. 6 T410, A216 (WCB/WCC), A182 (Gr.: F1/F5/F5a/F9/F11/F22/F44/F51/F53/F91/F304/F304L/F316/F316H/F316L/F321/F347/F347H), A240 316, A217 (C5/C12A/WC1/WC6/WC9), A350 (LF2/LF3), A351 (CD4MCu/CF3/CF3M/CF8/CF8C/CF8M/CK3MCuN), A352 (LC1/LC2/LC3/LCB/LCC), A453 Gr. 660B, A479 (T304/T304L/T316/T316L/T321), A494 (CW6MC/M35-1), B564 (N04400/N06625)



LRQA Inspection Iberia, S.A. is a company registered in the R. M. de Madrid, in Volume 5218 general, 4358, of Section Sec. 1.ª of the Companies Book, folio 133 sheet nº 41397, inscription. 1.ª C.I.F. - A28591287 - Registered office C/Princesa 29, 1ª. 28008 Madrid. A subsidiary of LRQA Group Limited.

LRQA Group Limited, its affiliates and subsidiaries and their respective officers, employees or agents are, individually and collectively, referred to in this clause as 'LRQA'. LRQA assumes no responsibility and shall not be liable to any person for any loss, damage or expense caused by reliance on the information or advice in this document or howsoever provided, unless that person has signed a contract with the relevant LRQA entity for the provision of this information or advice and in that case any responsibility or liability is exclusively on the terms and conditions set out in that contract.

EU CERTIFICATE SCHEDULE 0094/PED/MAD/0132 ENG

In accordance with the requirements of the Pressure Equipment
Directive 2014/68/EU.

Product (s)	Model	Design Standard/ Code	Size Range	Rating Range	Materials
	3-way Bellows seal			PN400	10273), 1.0619 (EN 10213), 1.0625 (EN 10213), 1.4308 (EN 10213), 1.4401 (EN 10222-5), 1.4404 (EN 10222-5), 1.4408 (EN 10213), 1.4409 (EN 10213), 1.4541 (EN 10222-5), 1.4550 (EN 10222-5), 1.4552 (EN 10213), 1.4571 (EN 10222-5), 1.4581 (EN 10213), 1.5415 (EN 10222-2), 1.6368 (EN 10216-2), 1.7335 (EN 10222-2), A105, A194 Gr. 6 T410, A216 (WCB/WCC), A182 (Gr.: F1/F5/F5a/F9/F11/F22/F44/F51/F53/F91/F304/F304L/F316/F316H/F316L/F321/F347/F347H), A240 316, A217 (C5/C12A/WC1/WC6/WC9), A350 (LF2/LF3), A351 (CD4MCu/CF3/CF3M/CF8/CF8C/CF8M/CK3MCuN), A352 (LC1/LC2/LC3/LCB/LCC), A453 Gr. 660B, A479 (T304/T304L/T316/T316L/T321), A494 (CW6MC/M35-1), B564 (N04400/N06625)
Choke	Positive Adjustable Control	ANSI B16.34 API 6A EN 12516	Up to: 20" DN500	Up to: 4500 # 20.000 psi PN400	1.0426 (EN 10222-2), 1.0460 (EN 10273), 1.0619 (EN 10213), 1.0625 (EN 10213), 1.0426 (EN 10222-2), 1.0460 (EN 10273), 1.0619 (EN 10213), 1.0625 (EN 1.0426 (EN 10222-2), 1.0460 (EN 10273), 1.0619 (EN 10213), 1.0625 (EN 10213), 1.4308 (EN 10213), 1.4401 (EN 10222-5), 1.4404 (EN 10222-5), 1.4408 (EN 10213), 1.4409 (EN 10213), 1.4541 (EN 10222-5), 1.4550 (EN 10222-5), 1.4552 (EN 10213), 1.4571 (EN 10222-5), 1.4581 (EN 10213), 1.5415 (EN 10222-2), 1.6368 (EN 10216-2), 1.7335 (EN 10222-2), A105, A194 Gr. 6 T410, A216 (WCB/WCC), A182 (Gr.: F1/F5/F5a/F9/F11/F22/F44/F51/F53/F91/F304/F304L/F316/F316H/F316L/F321/F347/F347H), A240 316, A217 (C5/C12A/WC1/WC6/WC9), A350



LRQA Inspection Iberia, S.A. is a company registered in the R. M. de Madrid, in Volume 5238 general, 4356, of Section Sec. 3 of the Companies Book, folio 133 sheet nº 41397, inscription, 1.ª C.I.F. - A28581287 - Registered office C/Princesa 29, 15, 28008 Madrid. A subsidiary of LRQA Group Limited.

LRQA Group Limited, its affiliates and subsidiaries and their respective officers, employees or agents are, individually and collectively, referred to in this clause as 'LRQA'. LRQA assumes no responsibility and shall not be liable to any person for any loss, damage or expense caused by reliance on the information or advice in this document or howsoever provided, unless that person has signed a contract with the relevant LRQA entity for the provision of this information or advice and in that case any responsibility or liability is exclusively on the terms and conditions set out in that contract.

**EU CERTIFICATE SCHEDULE
0094/PED/MAD/0132 ENG**

In accordance with the requirements of the Pressure Equipment
Directive 2014/68/EU.

Schedule Issue: 04
Date of Schedule Issue: 22 May 2023
Notified Body 0094

Cristel López, LRQA Decision Maker



LRQA Inspection Iberia, S.A. is a company registered in the R. M. de Madrid, in Volume 5218 general, 4356, of Section Sec. 3.ª of the Companies Book, folio 133 sheet nº 41397, inscription. 1.ª C.I.F. - A28581287 - Registered office C/Princesa 29, 1ª, 28008 Madrid. A subsidiary of LRQA Group Limited.

LRQA Group Limited, its affiliates and subsidiaries and their respective officers, employees or agents are, individually and collectively, referred to in this clause as 'LRQA'. LRQA assumes no responsibility and shall not be liable to any person for any loss, damage or expense caused by reliance on the information or advice in this document or howsoever provided, unless that person has signed a contract with the relevant LRQA entity for the provision of this information or advice and in that case any responsibility or liability is exclusively on the terms and conditions set out in that contract.

15 Appendix

15.1 Tightening torques, lubricants and tools

Table 15-1: *Tightening sequence*

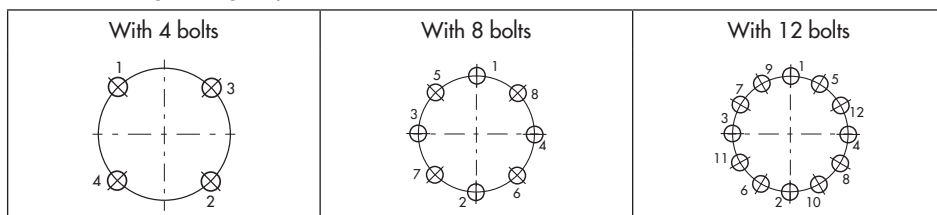

→ Tighten radial pressure-retaining bolting gradually in a crisscross pattern. Apply the target torque over several rounds.

Tightening torques

Table 15-2: *Tightening torques in Nm*

Thread size	Pressure-retaining bolting (355 and 455) (see Table 15-1 for tightening sequence)		Non-pressure-retaining bolting (1627) (any tightening sequence possible)	
	Material		Material	
	A193 B7	A453 660B	Gr. 8.8	A2-70
M10	30	30	30	10
M12	45	45	50	20
M14	70	75	80	30
M16	105	110	120	40
M18	145	155	170	55
M20	200	215	235	75
M22	270	285	310	100
M24	345	370	400	130
M27	500	535	585	190
M30	700	750	820	265

Appendix

Lubricant

Contact RINGO's After-sales Service Department for more information on suitable lubricants.

Tools

In addition to the standard tool, special tools are required to assemble and remove some parts. Use adjustable torque wrenches with a stop signal or that indicate the torque being applied to achieve the right tightening torques. Valves in large nominal sizes often require tightening torques that can only be achieved through additional torque multiplication by using a torque multiplier or hydraulic power tool.

The required special tools can be purchased from RINGO.

→ Contact our after-sales service.

Table 15-3: *Special tool to insert packing*

Description	Application
Either a packing tool or bushing halves can be used to slide the packing rings over the actuator stem into the packing chamber and compress them.	 A technical diagram showing a cross-section of a valve stem assembly. A central vertical stem passes through a packing chamber. Two packing rings are positioned on the stem. A special tool, consisting of two bushing halves, is shown being used to slide the packing rings onto the stem. Arrows indicate the direction of movement for the tool halves and the packing rings.

Table 15-4: *Special tool to mount and remove the trim (cage/seat ring)*

Presentation	Application
	

15.2 Spare parts

A1	Actuator	813	Drive rod
A2	Actuator	931	Balancing cylinder
5	Body	933	Guide bushing
15	Flat plug	1171	Locking pin
20	Bonnet	1419	Washer
26	Cage	1535	Drive rod
60	Plug stem	1536	Rod pin
61	Actuator stem	1537	Guide bushing stop
70	Seat ring	1539	Slip bushing
121	Spacer sleeve	1622	Guide bushing (actuator stem)
140	Plug stem extension	1623	Bushing (actuator stem)
165	Connecting flange	1624	Bushing
171	Retaining ring	1625	Bushing
220	Packing	1627	Bolt
254	Seal	1629	Locking pin
260	Seal	1632	Nut
294	O-ring (body)	1773A	O-ring (cage)
315	O-ring (bonnet)	1773B	O-ring (cage)
325	O-ring (seat)	1878	Spacer sleeve
335	O-ring (plug stem)		
355	Bolt		
391	Stud		
392	Nut		
453	Spring washer		
455	Bolt		
485	Threaded pin		
490	Nut		
500	Key drive		
525	Washer		
545	Washer		
557	Thrust washer		
571	Rod pin		
625	Yoke		
660	Drain screw		
717	Threaded pin (bonnet)		

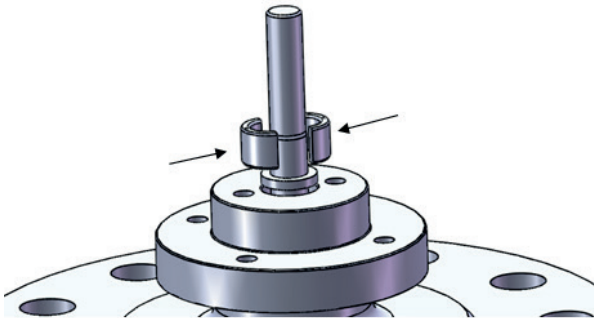
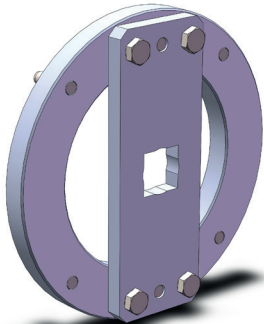
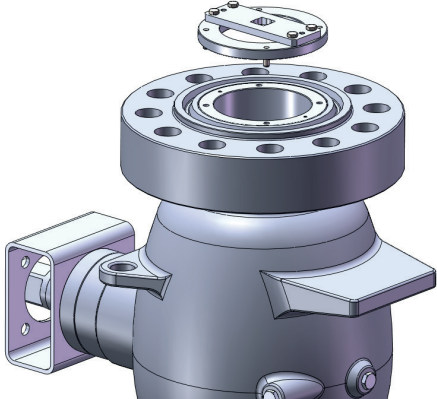
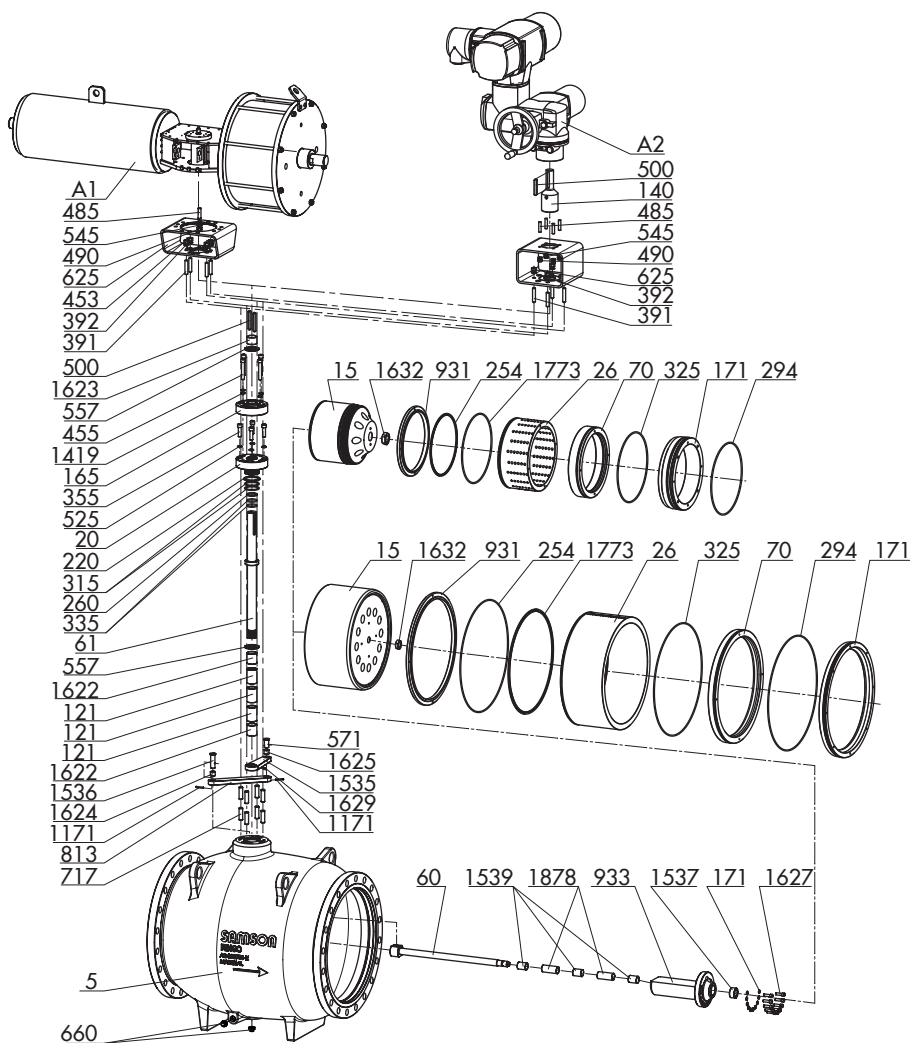

15.3 After-sales service

Contact our after-sales service for support concerning service or repair work or when malfunctions or defects arise.

E-mail address

You can reach our after-sales service at Aftersales-ringo-es@samsongroup.com.

Address of manufacturer

RINGO VÁLVULAS S.L.
Calle Romero N°6 Polígono Industrial
Empesarium
50720 Zaragoza · Spain

Addresses of SAMSON AG and its subsidiaries

The addresses of SAMSON AG, its subsidiaries, representatives and service facilities worldwide can be found on our website (www.samsongroup.com) or in all SAMSON product catalogs.

Required specifications

Please submit the following details:

- Order number and position number in the order
- Type, model number, nominal size and valve version
- Pressure and temperature of the process medium
- Flow rate in m³/h
- Direction of flow
- Bench range of the actuator (e.g. 0.2 to 1 bar)
- Is a strainer installed?
- Installation drawing

EB 8080 EN

SAMSON RINGO

RINGO VÁLVULAS S.L.

Calle Romero N°6 Poligono Industrial Empresarium

50720 Zaragoza · Spain

Phone: +34 976 45 49 40 · email: info-ring-es@samsongroup.com

Internet: www.ringospain.com